



TDD 1™ Tablet De-Duster User Manual



We don't just sell machines—
we provide service.

Copyright Notice

© LFA Machines Oxford Limited, published in 2026 by LFA Machines Oxford Limited 2026. Registered in England and Wales, company number 08428898, registered office for service Demar House 14 Church Road East Wittering, Chichester, West Sussex, PO20 8PS.

All rights reserved. No part of this publication may be reproduced or transmitted, in any form or by any means, or stored in any retrieval system of any nature, without prior permission, except for fair dealing under the Copyright, Designs and Patents Act 1988, or in accordance with the terms of license issued by the Copyright Licensing Agency in respect of photocopying and/or reprographic reproduction. Application for permission for other use of the copyright material including permission to reproduce extracts in other published works shall be made to the publisher. Full acknowledgment of author, publisher and source must be given.

All trade marks are acknowledged and are owned by their respective owners.

Important Safety Information

READ THIS BEFORE OPERATING MACHINE

Intended Use

The intended use of this machine is to remove excess powder from tablets after pressing.

Potential misuse of this machine includes:

- Attempting to de-dust capsules.
- Attempting to de-dust tablets outside of the 4-13 mm size range.
- Operating the machine without a vacuum.
- Not installing the machine on stable ground.
- Using wet or damp material.

Personal Protection

For personal protection while transporting the TDD 1™, abide by these actions:

- Wear steel toe boots to prevent foot injury.
- Wear heavy duty grip gloves to ensure firm grasp on machine.
- Wear back support belt to prevent injury if needed.

For personal protection while operating the TDD 1™, abide by these actions:

- Avoid wearing loose jewelry to prevent machine entanglement.
- Contain long hair to prevent machine entanglement.
- Wear safety goggles.
- Wear disposable latex/rubber gloves.
- Wear a hairnet (food grade products only).
- Wear a beard net if needed (food grade products only).

General Hazards

- Do not operate in a wet environment or with wet hands due to risk of electrical shock or burn.
- Do not operate if any wires are damaged, pinched, or frayed due to risk of electrical shock or burn.
- Keep out of reach of children.
- Keep fingers away from all moving parts.
- Inspect machine before use.
- Check that nuts and bolts are suitably tightened.
- Use this machine only for its intended use as described in this manual.
- Turn off and unplug the machine before conducting cleaning and maintenance.
- Do not modify the machine in any way.

Safety Assessment

It is critical to conduct a safety assessment to ensure that it complies with all local laws and industry accepted safety regulations.

If you require guidance on the installation of the machine or conducting a safety assessment, please contact LFA Machines.

Important Safety Information

READ THIS BEFORE OPERATING MACHINE

Symbols



WARNING

This signals potential risk for personal injury.



CAUTION

This signals potential risk for damage to the machine or other parts.

Modes for Stopping

In the case of an emergency during operation, immediately press the red OFF button (see below) and unplug.



Prop. 65 Statement for CA Residents

Based on LFA's current level of knowledge of our machines, the TDD 1™ does not require a Proposition 65 warning label.

Warning for Explosive Material

This machine is not explosion proof. LFA recommends that you test your materials' explosivity before running them through this machine. If your materials are indeed explosive, do not use them with this machine.

Table of Contents

Copyright Notice	2
Intended Use	3
Personal Protection	3
General Hazards	3
Safety Assessment	3
Symbols	4
Modes for Stopping	4
Prop. 65 Statement for CA Residents	4
Warning for Explosive Material	4
TDD 1™ Parts List	6
Preface	7
Training	8
Off-Site Training	8
Training via Video Chat/Phone	8
LFA Articles	8
LFA Videos	8
Installation	9
Tools and Materials Needed	9
The Appropriate Workstation for the Machine	9
Positioning the TDD 1™	11
Assembly	12
Controls	14
Settings and Adjustment	17
Maintenance	20
General Maintenance Prescriptions	20
Repair and Replacement	20
Troubleshooting	21
Common Machine/Part Issues	21
De-Jamming the TDD 1™	22
Cleaning	24
Storing the TDD 1™	27
Appendix	27
Glossary	27
Description of TDD 1™ Parts	28
Material of Contact Parts	29
Technical Specifications	29
Maintenance Checklist	30
Resources	33

TDD 1™ Parts List

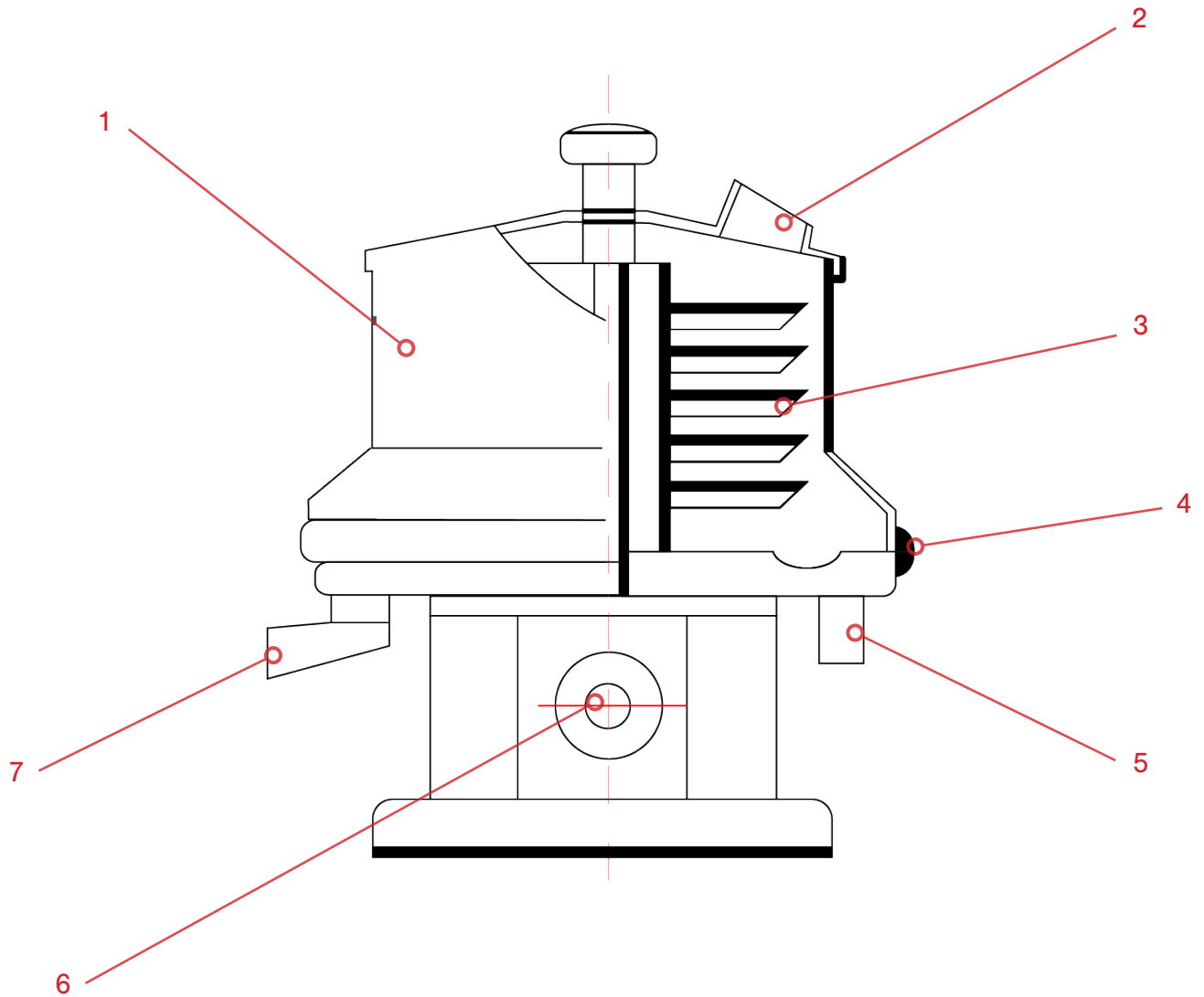

- 1. Outer Cover
- 2. Tablet Feeder
- 3. Sifter Tray
- 4. Rubber Gasket

- 5. Vacuum Cleaner Connection
- 6. Speed Adjustment Dial
- 7. Discharge Chute

Preface



The TDD 1™ Tablet De-Duster removes excess powder from tablets using compressed air and a vacuum. The tablets simultaneously move around a five-layer agitation plate, which loosens any residual dust. With the ability to clean more than half a million tablets an hour, this machine can also be used in conjunction with a tablet press so that the tablets pour into the de-duster right after being pressed.

The purpose of this document is to support your understanding of the TDD 1™'s components, features, functions, and design. With this manual, you will be able to successfully operate and maintain your TDD 1™ machine.

The user manual's content includes:

- Important safety information
- TDD 1™ installation instructions
- Description of the TDD 1™'s operation
- TDD 1™ maintenance information
- Appendix with supplemental information

Training

TDD 1™ training is essential for the machine's successful operation and your personal safety. There are several methods to prepare you for working with the TDD 1™.

Off-Site Training

LFA offers training at our UK, USA, and Taiwan facilities for all our customers and their teams. For more information, go to <https://www.lfatabletpresses.com/services>

Training via Video Chat/Phone

Using an online video chat system, an LFA technician can interact face-to-face with you and assist with your understanding of the machine. Or, if you prefer, LFA can provide training via phone for all customers who call the office. To set up a training, call or email your local LFA office:

UK

Phone

+44 01869 250234

Email

support.uk@lfamachines.com

USA

Phone

+1 (682) 312-0034

Email

support.usa@lfamachines.com

Taiwan

Phone

+886 422031790

Email

support.asia@lfamachines.com

LFA Articles

LFA writes informative articles about our machines, which includes instructions, procedures, and guides. To access the articles, go to <https://www.lfatabletpresses.com/articles>

LFA Videos

LFA has created videos involving our machines. To access the videos, go to <https://www.lfatabletpresses.com/videos> or <https://www.youtube.com/user/TabletPilPress>

Installation

Tools and Materials Needed

Before you install and operate the TDD 1™, it is best to have the following tools and materials on hand for general operation and maintenance:

- Hammer
- Crowbar
- Metric wrench set and adjustable wrench
- Flathead screwdriver
- Set of metric Allen keys with ball ends
- Bagless vacuum
- Dust collector vacuum (e.g. LFA's TabVac Tablet Dust Vacuum, which can be purchased at <https://www.lfatabletpresses.com/tabvac-tablet-dust-vacuum>)
- Air compressor
- Sanitizer (e.g. Member's Mark Commercial Sanitizer)
- Plastic sheet or something similar to cover machine
- Safety goggles
- Disposable latex/rubber gloves
- Hairnet and/or beard net (food grade products only)
- Sterile shoe covers (food grade products only)

The Appropriate Workstation for the Machine

Find stable, even flooring that supports the TDD 1™'s 38 kg (approximately 84 lbs) weight. This machine also has a single phase 220 V or 110 V ($\pm 10\%$) electrical requirement, so ensure that it is near an appropriate power plug.

Environmental Conditions

It is important that the environment in which you operate and store the TDD 1™ has the appropriate temperature and relative humidity levels. These two environmental factors can potentially cause the machine to rust and/or cause the tablets to have a lower quality. The table below shows the acceptable temperature and relative humidity levels:

Machine	Temperature		Humidity
TDD 1™	°C	°F	45-65% RH
	18-24	64-75	

The shipping crate will contain the following:

1. The fully assembled TDD 1™



2. Air hoses and fittings for de-duster

Unpacking the TDD 1™

Tools Needed

- Hammer
- Crowbar

Instructions

1. Pry open the panels of the shipping container with a hammer and crowbar.



2. Lift the top of the shipping container from its base.
3. Remove the stand and the de-duster boxes from the container.
4. Open the boxes, remove the stand and de-duster, and take off the plastic wrapping.
 - 4.1 Note: Save the wrapping for future transport and/or storage.

Positioning the TDD 1™



WARNING: To prevent personal injury, wear steel toe boots and heavy duty grip gloves while transporting the TDD 1™.

One or two people should be sufficient in removing the machine from the shipping container and positioning it in the workspace.

Assembly

The TDD 1™ comes fully assembled with a few minor installations.

Tools Needed

- Dust collector vacuum (e.g. LFA's TabVac Tablet Dust Vacuum, which can be purchased at <https://www.lfatabletpresses.com/tabvac-tablet-dust-vacuum>)
- Air compressor

Instructions

1. Place the de-duster onto its stand.



2. Connect the vacuum to the bottom of the machine.
3. Unscrew the knob and remove the top cover.



4. Lift up the sifter and remove it from the machine.
5. Secure the air fittings to the outer cover of the TDD 1™.



6. Connect the machine's air hoses to the air fittings and the air compressor.
7. Reassemble the sifter and top cover to the TDD 1™.

Controls

Basic Components



A description of the principal components follows:

- The **Base** contains the vibratory component that produces the power to move the tablets.
- The **Rod** holds the sifter in place.
- The **Sifter Tray** sieves the excess powder as the tablets are moved through the machine.
- The **Air Compressor** blows the excess powder off the tablets at the perforated tray at the bottom.
- The **Vacuum** removes the excess powder from the machine.

TDD 1™ Process

The basic mechanism of the TDD 1™ involves using an agitation system to loosen dust from tablets' surface as they pass through the machine.

Movement Caused by Vibration

Tablets are pushed through the machine via vibration and down the sifter tray. During this time, dust is shaken off from the tablets and sieved through the sifter tray.

Further Removal of Dust by Air Compressor and Vacuum

Once the tablets reach to the perforated bottom tray, the air compressor blows off any remaining debris. After that, all the dust is removed by the vacuum and the de-dusted tablets come out of the discharge chute.



How to De-Dust Tablets with the TDD 1™

Tools and Materials Needed

- Tablets with a friability of less than 1%
- TDD 1™ with vacuum cleaner and air compressor
- Receptacle to catch de-dusted tablets
- Safety goggles
- Disposable latex/rubber gloves (for food grade products and to protect hands from grease)
- Hairnet and/or beard net (food grade products only)
- Sterile shoe covers (food grade products only)



WARNING: For personal protection while operating the TDD 1™, contain long hair and do not wear loose jewelry.

Instructions

Note: Wear latex/rubber gloves (and appropriate food grade attire if applicable) during this process.

1. Press the ON button on the control panel and the vacuum cleaner.



2. Insert several tablets into the feeder for a test run.

2.1 Note: Adjust the speed on the machine and watch for any abnormality in operation.

3. Pour the rest of the tablets into the feeder.



4. Catch the ejected de-dusted tablets from the discharge chute at the bottom of the machine.
5. Lower the operation speed to the minimum and press the OFF button on the control panel and the vacuum cleaner whenever all tablets have been de-dusted.

Settings and Adjustment

Operation Speed

The TDD 1™ vibration speed can be adjusted by turning a dial on the control panel.

Tools and Materials Needed

- Safety goggles
- Disposable latex/rubber gloves (for food grade products and to protect hands from grease)
- Hairnet and/or beard net (food grade products only)
- Sterile shoe covers (food grade products only)



WARNING: For personal protection while operating and adjusting the TDD 1™, contain long hair and do not wear loose jewelry.

Instructions

Note: Wear latex/rubber gloves (and appropriate food grade attire if applicable) during this process.

1. Press the ON button on the control panel.
2. Pour in the tablets into the machine's feeder at the top.
3. Rotate the dial on the control panel to adjust the operation speed.

3.1 Note: Rotate the dial clockwise to increase the operation speed, and rotate the dial counterclockwise to decrease the operation speed. If tablets are coming out dusty, the machine will need to be slowed down. If the tablets are coming out clean but are becoming backed up in the sifter, the machine will need more speed.

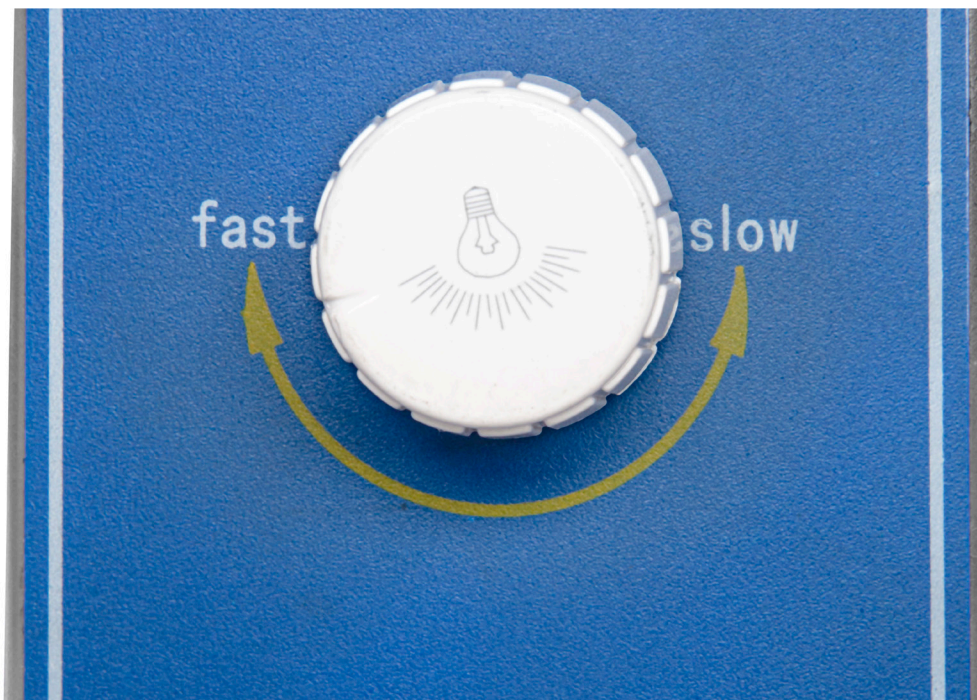

Stand Height

The stand height of the TDD 1™ can be adjusted to help with integrating it with a tablet press.

Tools and Materials Needed

- Disposable latex/rubber gloves (for food grade products and to protect hands from grease)
- Hairnet and/or beard net (food grade products only)
- Sterile shoe covers (food grade products only)



WARNING: To prevent any potential personal injury, unplug the TDD 1™ from the electrical outlet and wear steel toe boots and heavy duty grip gloves while moving the TDD 1™. One or two people should be sufficient in moving the machine.

Instructions

Note: Wear latex/rubber gloves (and appropriate food grade attire if applicable) during this process.

1. Remove the TDD 1™ from the stand.



2. Turn the stand's adjustment handle counterclockwise.



3. Place the TDD 1™ back on the stand.

3.1 Note: Have the TDD 1™'s tablet feeder near the discharge chute of the tablet press.

4. Using the TDD 1™'s weight, place pressure on the stand to adjust the height.

5. Turn the stand's adjustment handle clockwise to lock the stand's height position in place.

Maintenance

To ensure that the TDD 1™ will have a long operational life, maintenance is essential. This section includes methods for troubleshooting solutions and how often to clean your machine to keep its performance optimal.

General Maintenance Prescriptions

- Use the maintenance checklist (found in the Appendix) before, during, and after machine operation.
- Unplug the machine before cleaning.
- Before reassembling the machine after cleaning, make sure that the parts are dried.
- Constantly check for any loose nuts and/or screws before, during, and after machine operation.

Repair and Replacement

Some parts of the TDD 1™ may need to be removed for repair and replacement.

Warranty

To access LFA's warranty policy, go to <https://www.lfatabletpresses.com/warranty>

If your part is eligible for warranty, have your part's serial number on hand and please contact LFA:

UK

Phone

+44 01869 250234

Email

support.uk@lfamachines.com

USA

Phone

+1 (682) 312-0309

Email

support.usa@lfamachines.com

Taiwan

Phone

+886 422031790

Email

support.asia@lfamachines.com

Troubleshooting

Sometimes unavoidable issues will occur while operating the TDD 1™. Fortunately, there are several methods to remedy these issues.

Common Machine/Part Issues

Symptom	Possible Cause	Possible Solution
Machine does not vibrate after being turned on	The power plug is loose from outlet or from the machine.	Re-connect the power plug to the machine and the outlet. If the machine still doesn't operate after this, consult an electrician.
	The machine is not turned on.	Ensure that the machine is turned on.
	The operation speed is set too low.	Increase the operation speed.
Tablets are not being passed through the sifter tray	There is damage to the sifter tray.	Check the sifter for any abnormalities/damage and change if needed.
	The machine is not on even ground.	Level the machine so that it is on even ground.
	The vibration is too high or too low.	Adjust the machine's vibration.
Abnormal noise is coming from the machine	There are loose parts or loose nuts and bolts.	Check all parts in the machine and tighten any loose nuts and bolts.
Tablets are backing up in the machine and not coming out de-dusted	Too many tablets are being fed into the machine.	Reduce the amount of tablets to be de-dusted.

De-Jamming the TDD 1™

Sometimes tablets may get jammed in the machine's sifter tray.

Tools and Materials Needed

- Level
- Disposable latex/rubber gloves (for food grade products and to protect hands from grease)
- Hairnet and/or beard net (food grade products only)
- Sterile shoe covers (food grade products only)



WARNING: To prevent any potential personal injury, ALWAYS unplug the TDD 1™ before de-jamming it.

Instructions

Note: Wear latex/rubber gloves (and appropriate food grade attire if applicable) during this process.

Check the Machine's Sifter Tray

1. Loosen the knob and remove the top cover.



2. Lift up the sifter tray and inspect it for any damage.

2.1 Note: If damaged, the TDD 1™ may be eligible for warranty. Please see LFA's warranty policy at <https://www.lfatabletpresses.com/warranty>.



3. Replace the sifter tray if damaged or clear any tablet blockages.

Level and Balance the Machine

1. Use a level to ensure that the TDD 1™ is balanced on the floor.
 - 1.1 Note: If it is not level, move the machine to a flat surface.



Cleaning

During the TDD 1™'s operation, excess powder will find its way into parts of the machine. It is important to clean the TDD 1™ thoroughly to prevent rusting and cross contamination.

LFA recommends that the machine be cleaned after each operation.

Tools and Materials Needed

- Cleaning brush
- Toothbrush
- Disposable latex/rubber gloves
- Bagless vacuum
- Clean cloths
- Potable water
- Sanitizer (e.g. Member's Mark Commercial Sanitizer)
- Hairnet and/or beard net (food grade products only)
- Safety goggles
- Sterile shoe covers (food grade products only)



WARNING: To prevent any potential personal injury, ALWAYS unplug the TDD 1™ from the electrical outlet when replacing parts.

Instructions

Note: Wear safety goggles and latex/rubber gloves (and appropriate food grade attire if applicable) during this process.

Remove the Machine Parts

1. Loosen the rod's knob and remove the top cover.



2. Lift up and remove the sifter tray from the machine.
3. Remove the outer cover and bottom sieve.



Clean the Machine Parts

4. Vacuum the bottom of the machine.
5. Use the sanitizer on all non-metal parts/surfaces on the machine and machine parts.
6. Use potable water to clean the sanitizer.
 - 6.1 Note: Do NOT use alcohol to clean the non-metal parts of the machine.
7. Place the cleaned outer cover into the rubber gasket.
8. Insert the cleaned sifter tray back over the rod.
9. Place the cleaned top cover on top of the sifter tray and secure it with the top knob.

Cleaning Schedule Matrix

Part	Frequency							
	After installing machine	After every use	Before every use	In between products that present a cross contamination risk	Weekly	Monthly	Before placing in storage	After removing from storage
Outer Cover and Top Cover	Remove from machine	Clean on machine	Remove from machine	Remove from machine	Clean on machine	Clean on machine	Clean on machine	Remove from machine
Machine Body (outside machine)	Clean on machine	Clean on machine	Remove from machine	Clean on machine	Clean on machine	Clean on machine	Clean on machine	Clean on machine
Sifter Tray	Remove from machine	Clean on machine	Remove from machine	Remove from machine	Clean on machine	Clean on machine	Clean on machine	Remove from machine
Hoses	Remove from machine	Clean on machine	Remove from machine	Clean on machine	Clean on machine	Clean on machine	Clean on machine	Remove from machine
Tablet Feeder and Discharge Chute	Clean on machine	Clean on machine	Clean on machine	Clean on machine	Clean on machine	Clean on machine	Clean on machine	Clean on machine

Cleaning Level Key	
Level 1 - Remove powder	
Level 2 - Dry clean with cloth	
Level 3 - Dry clean and re-lubricate if specified in lubrication schedule	
Level 4 - Wet clean and re-lubricate if specified in lubrication schedule	
Remove from machine - Take part out of machine and clean if required. Store it correctly or install back into machine.	
Install into machine - Install part into the machine and make sure that it has been cleaned. If needed, lubricate to the level required.	
Clean on/in machine - Clean the part while in the machine and do not remove it. Make sure that all contact surfaces are clean to the level required.	

This cleaning matrix is intended as a guide only and is not an exhaustive list. All cleaning schedules will need to be adapted to the industry and product, following industry regulations and the material safety data sheets that come with specific products. Please check with your Food Safety Manager/Department, Quality Control Manager/Department, or other relevant internal departments at your company before using.

Storing the TDD 1™

After its thorough cleaning, the TDD 1™ needs to be stored in the proper conditions. It is important to store it in an environment in which the machine is safe from rusting.

Tools and Materials Needed

- Plastic wrapping to cover machine
- Disposable latex/rubber gloves (for food grade products and to protect hands from lubricant)
- Hairnet and/or beard net (food grade products only)
- Sterile shoe covers (food grade products only)

Instructions

Note: Wear latex/rubber gloves (and appropriate food grade attire if applicable) during this process.

Cover the TDD 1™

1. Carefully cover the TDD 1™ with the plastic wrapping.

1.1 Note: You can use the plastic wrapping that came with the machine in the shipping container.

Environmental Conditions

It is important that the environment in which you store the TDD 1™ has the appropriate temperature and relative humidity levels. These two environmental factors can potentially cause the machine to rust. The table below shows the acceptable temperature and relative humidity levels:

Machine	Temperature		Humidity
TDD 1™	°C	°F	45-65% RH
	15-28	59-83	

Appendix

Glossary

Term	Definition
API/Active Pharmaceutical Ingredient	Any substance or mixture of substances used that is an active ingredient in the drug product.
Binding agent	See excipient.
Excipient	An inactive substance that serves as the vehicle or medium for a drug or other API.
Formulation	Powder mix of the excipient and the API that is compressed to make tablets.
Friability	The tendency of a tablet to break into smaller pieces during contact.
TDD 1™	LFA trademarked term for tablet de-duster.

Description of TDD 1™ Parts

Outer Cover

The Outer Cover prevents excess tablet powder from escaping the machine and into the workspace.



Top Cover

The Top Cover has a feeder inlet for the tablets and can be removed.



Control Panel

The Control Panel includes the ON/OFF button and the dial that adjusts the operation speed.



Sifter Tray

The Sifter Tray carries the tablets down through the machine while removing the dust from them.



Material of Contact Parts

Contact Part	Material
Outer Cover	Perspex
Top Cover	Perspex
Sifter Tray	304SS
Discharge Chute	304SS

Technical Specifications

Capacity (tablet/h)	550,000
Minimum/maximum tablet size	4 mm/13 mm
Power supply	220 V or 110 V ($\pm 10\%$) 50 Hz or 60 Hz 1 phase
Compressed air	20 Pa
Vacuum cleaning	1.8 m ² /min–0.01 MPa
Dimensions (mm)	315 x 350 x 900-1070
Dimensions with suggested working clearance (mm)	1215 x 1250 x 1800-1970
Weight (kg)	38

Maintenance Checklist

Before Operation	
<input type="checkbox"/>	Visually inspect the de-duster and the parts.
<input type="checkbox"/>	Ensure that all wires are connected and that a proper electrical outlet is nearby (single phase 220 V or 110 V [$\pm 10\%$]).
<input type="checkbox"/>	If to be incorporated with a tablet press, the TDD 1™ Feeder must be near the Discharge Chute of the tablet press.
<input type="checkbox"/>	Ensure the piping and connectors are properly installed.
<input type="checkbox"/>	Ensure that the machine is stable on the ground.
<input type="checkbox"/>	Conduct a test run for the machine with a few tablets and slowly adjust the operation speed. Watch out for any abnormalities such as excess noise or vibration.
During Operation	
<input type="checkbox"/>	During a regular run, listen for irregular knocking or clicking sounds. If heard, stop operation and investigate the source of the sound.
<input type="checkbox"/>	Watch for buildup of powder in the Sifter and corrugated tube. If occurring, clear the buildup with a cleaning brush or vacuum.
<input type="checkbox"/>	If needed, adjust the clearance between the armature and the electromagnet.
<input type="checkbox"/>	Inspect the de-dusted tablets for any damage once they come out from the machine.
After Operation	
<input type="checkbox"/>	Unplug machine and remove all excess powder with a bagless vacuum.
<input type="checkbox"/>	Open the Outer Cover and clean the inside of the machine (e.g. Sifter Tray).
<input type="checkbox"/>	Wipe down the other surfaces with a damp cloth.

TDD 1™ Dimensions

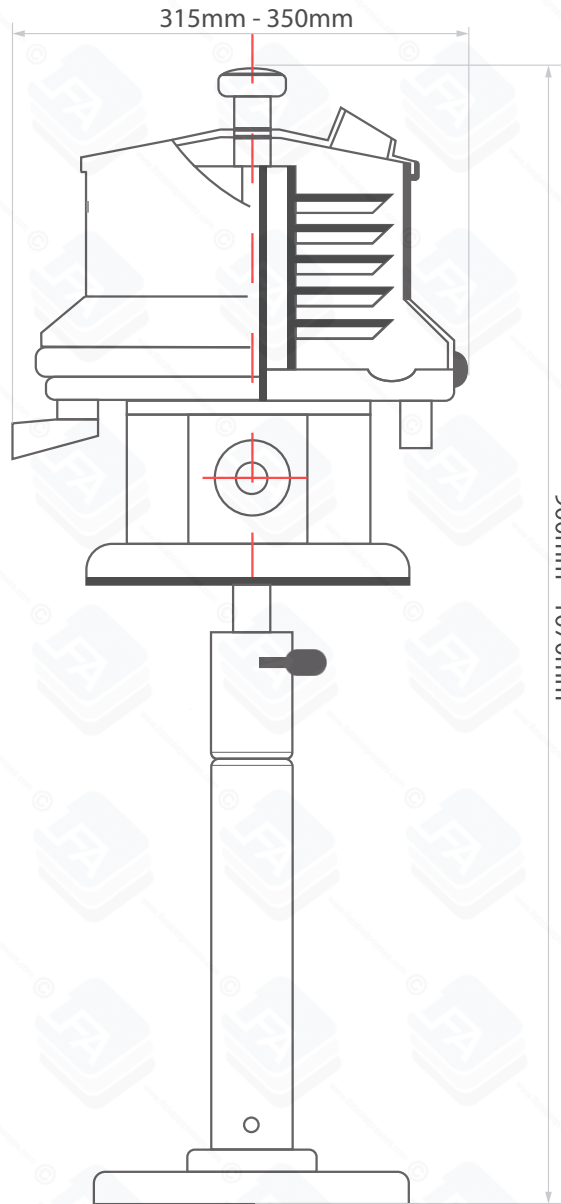

 www.lfamachines.com	Drawing Name	TDD1 Dimensions
	Product Name	TDD1
	Version	1.0
	Provided By	LFA Machines

TDD 1™ Electrical Drawing

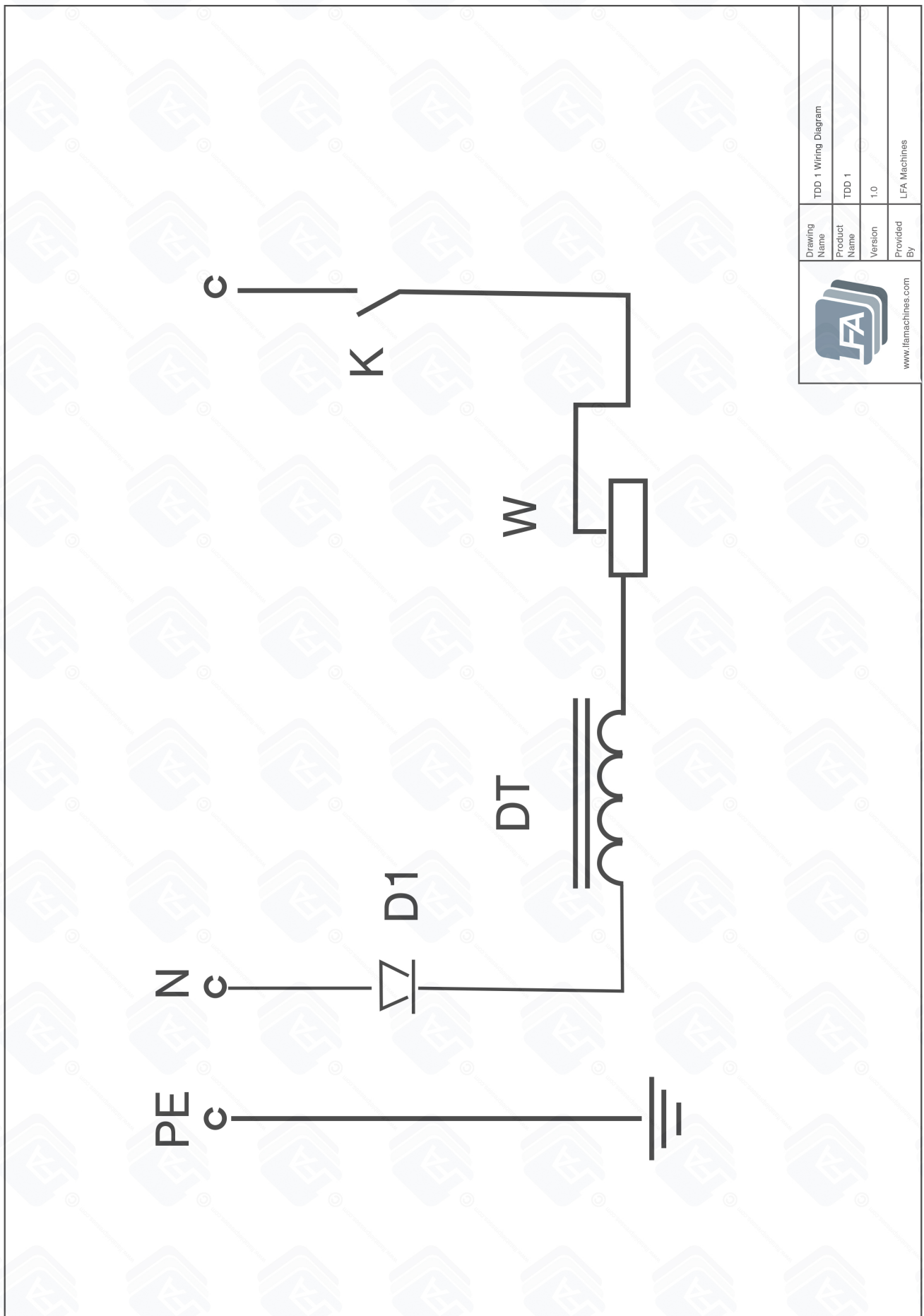

Drawing Name	TDD 1 Wiring Diagram
Product Name	TDD 1
Version	1.0
Provided By	LFA Machines

www.lfamachines.com

Resources

Helpful Links

Warranty

For information regarding the warranty policy of the TDD 1™ and other LFA products, please visit <https://www.lfatabletpresses.com/warranty>

LFA Website

In order to aid you in your tablet production, LFA Machines maintains a website that offers a breadth of useful information about our machines. Use our online tools such as the Tablet Mix Calculator to help you in your formulation production or read our regularly published articles that cover a whole range of topics about tablet presses and tablet production.

Visit the LFA homepage at <https://www.lfatabletpresses.com>

LFA Machines YouTube Channel

Our YouTube videos provide you an opportunity to see how to use our tablet presses, common troubleshooting tips, and other LFA products such as capsule fillers and mixers. We regularly upload videos to give you a visual aid that will hopefully support you in your tablet production efforts. To watch our videos, visit <https://www.youtube.com/channel/UCwtbcwja77ai7vX2o34FUkQ>

LFA Machines Social Media

Social media is a great way to keep yourself updated on new developments and exciting things happening at LFA Machines. The list below contains our current social media pages:

Twitter: @lfatabletpress

Facebook: <https://www.facebook.com/lfatabletpresses>

LinkedIn: <https://www.linkedin.com/company/lfa-machines-oxford-ltd/>

Contact Us

UK

LFA Machines Oxford Ltd
Unit 4B Rowood Estate
Murdock Road
Bicester, Oxfordshire OX26 4PP
+44 01869 250234
support.uk@lfamachines.com
Monday-Friday
9AM-5PM GMT

USA

LFA Machines DFW, LLC
6601 Will Rogers Blvd
Fort Worth, TX 76140
+1 (682) 312 0034
support.usa@lfamachines.com
Monday-Friday
8AM-6PM UTC (Central)

Germany

LFA Machines Düsseldorf GmbH
Business Parc Am Trippelsberg 92
Düsseldorf, North-Rhine
Westphalia 40589
+41 21188250223
verkauf@lfamachines.com

Taiwan

LFA Machines Taiwan Ltd
7F-5, No. 2, Sec. 2 Taiwan Blvd
West District, Taichung City 403
Taiwan
+886 422031790
support.asia@lfamachines.com
Monday-Friday
9AM-5PM GMT+8



LFA MACHINES

Copyright © 2026 by LFA Machines

www.lfamachines.com

United Kingdom

Unit 4B
Murdock Road
Bicester
Oxfordshire
United Kingdom
OX26 4PP

United States

6601 Will Rogers Blvd
Fort Worth
Texas
United States
76140

Germany

Business Parc Am
Trippelsberg 92
Düsseldorf
Germany
40589

Taiwan

7F.-5, No. 2, Sec. 2
Taiwan Blvd., West Dist.,
Taichung City 403,
Taiwan