



RTP 41[®] Tablet Press User Manual



We don't just sell machines—
we provide service.

Copyright Notice

© LFA Machines Oxford Limited, published in 2026 by LFA Machines Oxford Limited 2026. Registered in England and Wales, company number 08428898, registered office for service Demar House 14 Church Road East Wittering, Chichester, West Sussex, PO20 8PS.

All rights reserved. No part of this publication may be reproduced or transmitted, in any form or by any means, or stored in any retrieval system of any nature, without prior permission, except for fair dealing under the Copyright, Designs and Patents Act 1988, or in accordance with the terms of license issued by the Copyright Licensing Agency in respect of photocopying and/or reprographic reproduction. Application for permission for other use of the copyright material including permission to reproduce extracts in other published works shall be made to the publisher. Full acknowledgment of author, publisher and source must be given.

All trade marks are acknowledged and are owned by their respective owners.

Important Safety Information

READ THIS BEFORE OPERATING MACHINE

Intended Use

The intended use of this machine is to press dry raw materials into tablet form.

Potential misuse of this machine includes:

- Applying too much force to the powder.
- Trying to fill the Dies with powder by hand.
- Inserting Tooling that is too big for the machine.
- Using powders that could explode under pressure.
- Using wet or damp material.

Personal Protection

For personal protection while transporting the RTP 41[®], abide by these actions:

- Use a forklift to lift the machine.
- Wear steel toe boots to prevent foot injury.
- Wear heavy duty grip gloves to ensure firm grasp on machine.
- Wear back support belt to prevent injury if needed.

For personal protection while operating the RTP 41[®], abide by these actions:

- Avoid wearing loose jewelry to prevent machine entanglement.
- Contain long hair to prevent machine entanglement.
- Wear safety goggles.
- Wear disposable latex/rubber gloves.
- Wear a hairnet (food grade products only).
- Wear a beard net if needed (food grade products only).

General Hazards

In the case of an emergency during operation, immediately push the Emergency Stop button.

- Be aware of risk of entanglement and pinch point due to moving parts.
- Do not operate in a wet environment or with wet hands due to risk of electrical shock or burn.
- Do not operate if any wires are exposed in cables due to risk of electrical shock or burn.
- Keep out of reach of children.
- Keep fingers away from all moving parts.
- Ensure that it is securely against the workspace surface.
- Inspect machine before use.
- Check that nuts and bolts are suitably tightened.
- Use this machine only for its intended use as described in this manual.
- Do not modify the machine in any way.
- Turn off and unplug the machine before conducting cleaning and maintenance.

Important Safety Information

READ THIS BEFORE OPERATING MACHINE

Symbols



WARNING

This signals potential risk for personal injury.



WARNING

This signals potential risk for electrical shock.



CAUTION

This signals potential risk for damage to the machine or other parts.

Modes for Stopping

In the case of an emergency during automatic operation, immediately push the Emergency Stop button, turn the isolator, and unplug the RTP 41®:

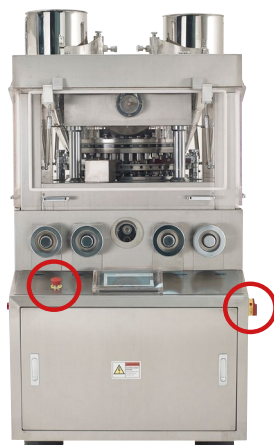

Prop. 65 Statement for CA Residents

Based on LFA's current level of knowledge of our machines, the RTP 41® does not require a Proposition 65 warning label.

Warning for Explosive Material

This machine is not explosion proof. LFA recommends that you test your materials' explosivity before running them through this machine. If your materials are indeed explosive, do not use them with this machine.

Important Safety Information

READ THIS BEFORE OPERATING MACHINE

Installation and Safety Assessment

Due to the nature and design of this machine and its intended use in an industrial environment, it is important that before use it is installed in a cage with a mode of stopping on the outside of the cage. LFA Machines has decided that we can not possibly foresee all of the environments or situations in which this machine could be used or installed and therefore have determined that the end user must install the machine in a way that is appropriate and safe for its use.

Once the machine has been installed, it is critical that you conduct a safety assessment to ensure that it complies with all local and industry accepted safety regulations.

If you require guidance on the installation of the machine or conducting a safety assessment, please contact LFA Machines.

This machine is sold as an Unfinished Machine under the Machinery Directive (2006/42/EC) Article 13.

Table of Contents

Copyright Notice	2
Important Safety Information	3
Intended Use	3
Personal Protection	3
General Hazards	3
Symbols	4
Modes for Stopping	4
Prop. 65 Statement for CA Residents	4
Warning for Explosive Material	4
Installation and Safety Assessment	5
RTP 41® Components	7
RTP 41® Electrical Components	8
Preface	9
Training	10
On-Site/Off-Site Training	10
Training via Video Chat/Phone	10
LFA Articles	10
LFA Videos	10
Installation	11
Tools and Materials Needed	11
The Appropriate Workstation for the Machine	11
Assembly	14
Positioning the RTP 41®	15
Controls	16
Settings and Adjustment	20
Maintenance	25
General Maintenance Prescriptions	25
Lubrication	25
Dismantling for Repair and Replacement	30
Wear Parts and Causes of Damage	31
Tooling	32
Take-Off Blades and Fill Trays Scrapers	37
Fill Trays	39
Lower Tracking	41
Upper Roller Cams	43
Troubleshooting	45
Common Machine/Part Issues	45
Common Tablet Issues	47
De-Jamming the RTP 41®	48
Cleaning	49
Storing the RTP 41®	52
Appendix	54
Glossary	54
Description of RTP 41® Parts	55
Material of Contact Parts	57
Technical Specifications	57
Maintenance Checklist	58
Diagrams	59
Resources	63

RTP 41[®] Components

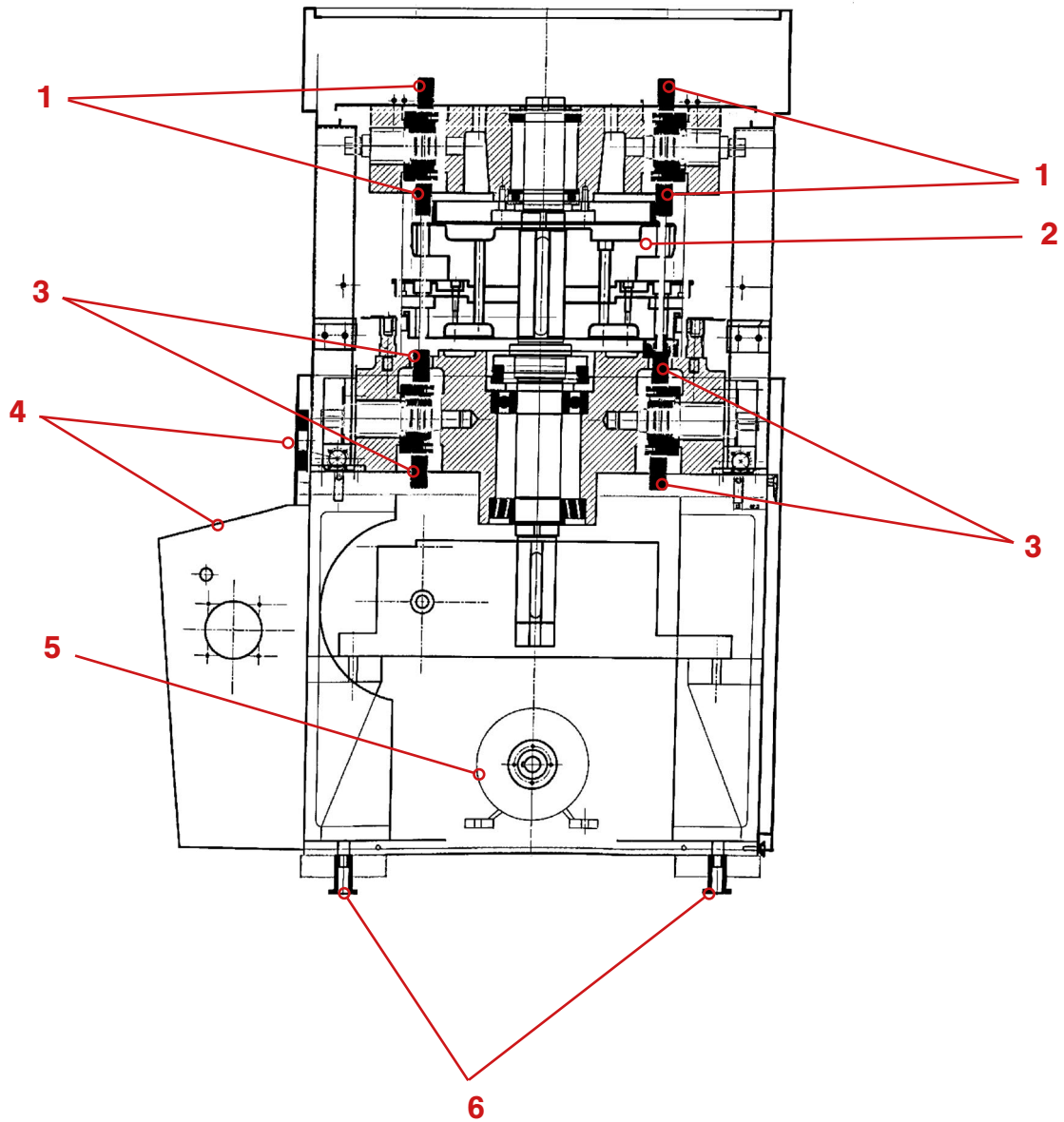

- 1. Upper Roller Cams
- 2. Turret
- 3. Lower Roller Cams
- 4. Adjustment Controls and HMI

- 5. Motor
- 6. Anti-Vibration Feet

RTP 41[®] Electrical Components



WARNING

Only qualified electricians should work with these controls.

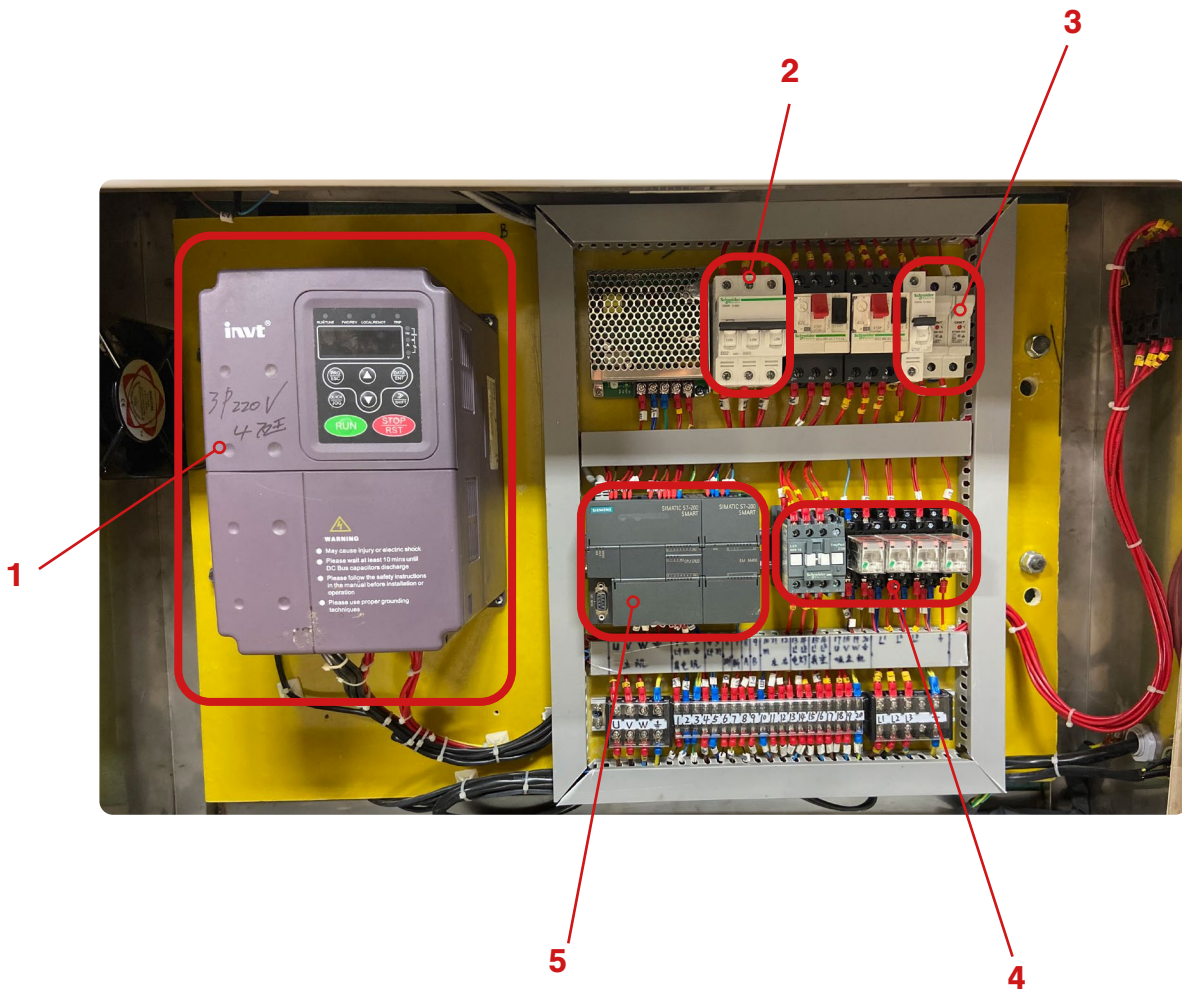

- 1. Variable Frequency Drive (VFD)
- 2. Breaker
- 3. Fuses
- 4. Solenoid switches

- 5. Programmable Logic Controller (PLC) for Human Machine Interface (HMI)

Preface



The RTP 41[®] is a high speed rotary tablet press that comes equipped with 41 sets of Tooling, electronic controls, and semi-automatic lubrication. With its 5.5 kW motor and up to 80 kN of maximum pressure, the RTP 41[®] can produce up to 180,000 tablets per hour in several types of shapes and forms. Particularly popular in the pharmaceutical, chemical, food, and electronic industries, the RTP 41[®] is the ultimate as a mass production unit in safety, speed, and feature set.

The purpose of this document is to support your understanding of the RTP 41[®]'s components, features, functions, and design. With this manual, you will be able to successfully operate and maintain your RTP 41[®] machine.

The user manual's content includes:

- Important safety information
- RTP 41[®] installation instructions
- Description of the RTP 41[®]'s operation
- RTP 41[®] maintenance information
- Appendix with supplemental information

Training

RTP 41[®] training is essential for the machine's successful operation and your personal safety. There are several methods to prepare you for working with the RTP 41[®].

On-Site/Off-Site Training

LFA technicians can travel and train you at your own facility with your own machines. LFA also offers training at our UK, USA, and Taiwan facilities for all our customers and their teams.

For more information, go to <https://www.lfatabletpresses.com/services>

Training via Video Chat/Phone

Using an online video chat system, an LFA technician can interact face-to-face with you and assist with your understanding of the machine. Or, if you prefer, LFA can provide training via phone for all customers who call the office. To set up a training, call or email your local LFA office:

UK

Phone

+44 01869 250234

Email

support.uk@lfamachines.com

USA

Phone

+1 (682) 312-0034

Email

support.usa@lfamachines.com

Taiwan

Phone

+886 422031790

Email

support.asia@lfamachines.com

LFA Articles

LFA writes informative articles about tablet presses, which includes instructions, procedures, and guides. To access the articles, go to <https://www.lfatabletpresses.com/articles>

LFA Videos

LFA has created several videos involving the RTP 41[®] and other tablet presses. To access the videos, go to <https://www.lfatabletpresses.com/videos> or <https://www.youtube.com/user/TabletPilPress>

Installation

Tools and Materials Needed

Before you install and operate the RTP 41[®], it is best to have the following tools and materials on hand for general operation and maintenance:

- Forklift that is rated to lift at least 2,000 kg
- Lifting straps that are rated for at least 2,000 kg
- Level
- Crowbar
- Hammer
- Rubber mallet
- Metric wrench set
- Crosshead screwdriver
- Flathead screwdriver
- Set of metric Allen keys with ball ends
- Long wire pipe cleaner
- Cleaner (e.g. Member's Mark Commercial Lemon Disinfectant)
- Sanitizer (e.g. Member's Mark Commercial Sanitizer)
- Lubricant (NSF approved type for food grade products)
- Grease gun
- Toothbrush
- Cleaning brush set
- Plastic sheet or something similar to cover machine
- Safety goggles
- Hairnet and/or beard net (food grade products only)
- Sterile shoe covers (food grade products only)

The Appropriate Workstation for the Machine

The floor on which the machine is to be placed must support the RTP 41[®]'s 1676 kg (approximately 3,696 lbs) weight. The static floor loading limit is 2.43 kN/m².

The machine's motor requires a three-phase power supply of 220 V or 440 V. Ensure to position the machine near an appropriate electrical plug

Environmental Conditions

It is important that the environment in which you operate and store the RTP 41[®] has the appropriate temperature and relative humidity levels. These two environmental factors can potentially cause the machine to rust and/or cause the tablets to have a lower quality. The table below shows the acceptable temperature and relative humidity levels:

Machine	Temperature		Humidity
	°C	°F	
RTP 41 [®]	18-24	64-75	45-65% RH

The shipping crate will contain the following:

1. The assembled RTP 41®



2. The Tooling (already installed)

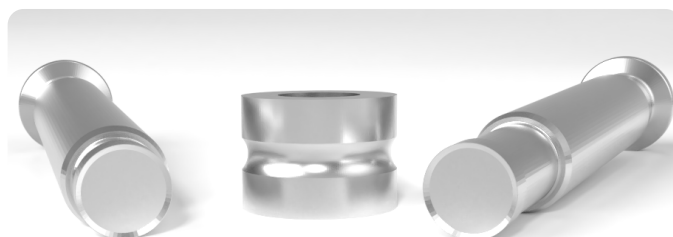

3. Toolkit including:



- Die Installation/Removal Bar
- Grease guns
- Crosshead screwdriver
- Flathead screwdriver
- Wrenches
- Allen key set

4. Eyelet bolts
5. Anti-vibration feet
6. Ejection Chute

Unpacking the RTP 41®

Tools Needed

- Crowbar
- Hammer
- Socket set or impact driver

Instructions

1. Remove the nuts and bolts from the shipping container's base with a socket set or impact driver.
 - 1.1 Note: Keep the nuts, bolts, and the shipping container's base in case you need to return the RTP 41®.
2. Pry apart the shipping container with a crowbar until the machine is accessible for a forklift.

Assembly

The RTP 41® also comes with anti-vibration feet to insert underneath its base's four corners. The anti-vibration feet not only absorb noise and vibrations, but also reduce the machine's movement. The anti-vibration feet's assembly must be done while the machine is suspended in the air with a forklift during its positioning.

READ BEFORE INSTALLATION:

Depending on local health and safety laws, the RTP 41® may be required to be installed in a cage. A risk assessment is required to be conducted before installation and operation of the machine.

LFA Machines is able to advise on this. Please contact us for more information:

UK

Phone

+44 01869 250234

Email

support.uk@lfamachines.com

USA

Phone

+1 (682) 312-0034

Email

support.usa@lfamachines.com

Taiwan

Phone

+886 422031790

Email

support.asia@lfamachines.com

Positioning the RTP 41®



WARNING: To prevent personal injury, wear steel toe boots and heavy duty grip gloves while transporting the RTP 41®.

Because of its 1677 kg (around 3,696 lbs) weight, LFA does NOT recommend carrying the machine manually but rather with a forklift. At least two people should be involved (one operating the forklift and one stabilizing the machine) in removing the machine from the shipping container and placing it in the workspace.

Moving the RTP 41® with a Forklift

Tools Needed

- Forklift that is rated to lift at least 2,500 kg
- Lifting straps that are rated for at least 2,500 kg
- Heavy duty grip gloves
- Steel toe boots

Instructions

1. Insert the eyelet bolts into the top of the machine.
 - 1.1 Note: Make sure that the eyelet bolts are securely tightened.
2. Feed the lifting straps through the eyelet bot.
3. Position the forks of a forklift truck over the top of the RTP 41® and securely attach the lifting straps.
4. Unbolt the RTP 41® from the metal pallet.
5. Carefully lift the RTP 41® off the pallet and attach the anti-vibration feet.
6. Lower the machine so that it is no more than 2-3 cm off the floor.
7. Position the RTP 41® in the desired location and carefully lower the machine.
8. Attach the Ejection Chute at the point of ejection with a crosshead screwdriver.

In accordance with Article 13 of the European Directive 2006/42/EC, LFA Machines sells the RTP 41® as a partly finished machine, and it is meant to be installed into and function as a part in a production line.



After the installation of this machine, the following measures need to be taken:

- **Shields must be installed in order to cover moving parts, those being in particular the Turret, Upper Punches, and Hoppers.**
- **An emergency stop/emergency lockout/isolator switch must be installed on the outside of the machine.**
- **A risk assessment must be conducted on the entire production line.**

If you require guidance on the installation of the machine or conducting a safety assessment, please contact LFA Machines.

Controls

Basic Components



A description of the principal components follows:

- The **Hoppers** hold the dry materials that will be compressed.
- The **Fill Trays** distributes the dry materials into the Die bores and their Take-Off Blades pushes tablets into the Ejection Chute.
- The **Dies** define the size and shape of the powder.
- The **Upper Punches** and **Lower Punches** compress the materials within the Dies.
- The **Turret** houses the Tooling.
- The **Upper Roller Cams** and **Lower Roller Cams** compress the Upper Punches and Lower Punches to create the tablet.

Control Console

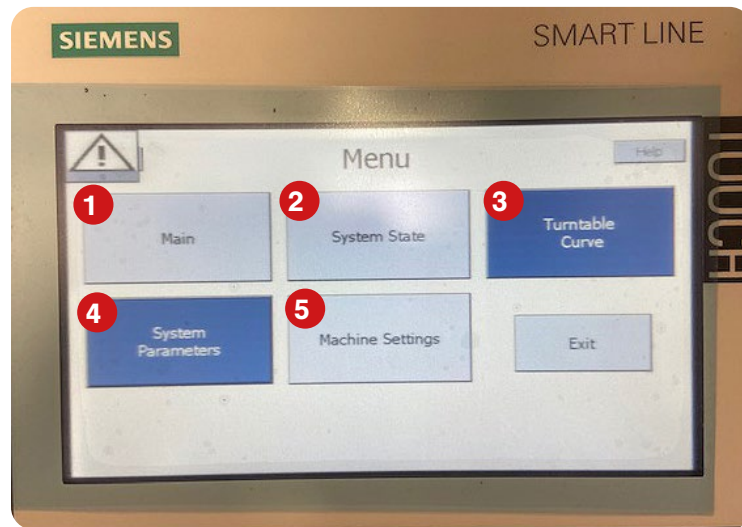

1. Main operation control
2. Start/stop auxiliary machines (de-duster, Fill Trays)
3. Graph of machine speed
4. Parameters of speed, output, and run time
5. Settings for screen appearance, alarms, date, and other parameters

Main Operation Control

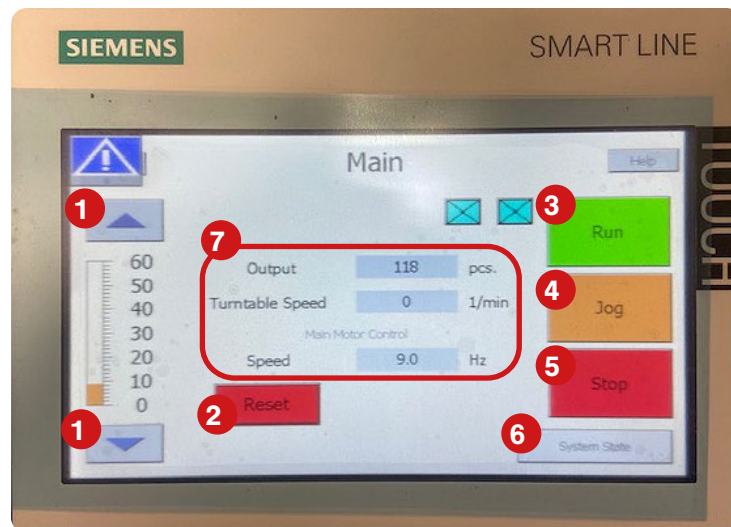

1. Adjusts machine speed
2. Clears Output count
3. Operate machine
4. Operate machine in small increments
5. Stop machine operation
6. Start/stop auxiliary machines
7. Displays tablet output, Turret rotations per minute, and speed in Hz

RTP 41® Process

The basic mechanism of the RTP 41® involves filling the Tooling (Dies, Upper Punches, and Lower Punches) with powder, compressing the powder, and ejecting the tablets.

Filling the Tooling with Powder

The dry materials are poured into the Hoppers and funneled into the Fill Trays. As the machine operates, the Turret moves, which causes the Upper Punches to withdraw from the Dies. During this process, powder makes its way from the Fill Trays into the moving Turret and the Die bores.

Compressing the Powder

After the Die bore is filled with powder, the Upper Punch is driven into the Die. The Upper and Lower Punches then compress the powder under high pressure.



Ejecting the Tablet

After both punches compress the powder into a tablet, the Upper Tooling is withdrawn and the tablet is then pushed out of the Die bore by the Lower Punch. Once the tablet has been ejected out of the Die bore, it is slid out of the way by the Fill Trays' Take-Off Blade to prepare for the next tablet compression.



How to Create Tablets with the RTP 41®

Tools and Materials Needed

- Raw material formulation
- RTP 41®
- Receptacle for finished tablets
- Safety goggles
- Disposable latex/rubber gloves (for food grade products and to protect hands from grease)
- Hairnet and/or beard net (food grade products only)
- Sterile shoe covers (food grade products only)



WARNING: To prevent any potential personal injury, unplug the RTP 41® from the electrical outlet when manually operating the machine.

Instructions

Note: Wear latex/rubber gloves (and appropriate food grade attire if applicable) during this process.

1. Place the receptacle near the machine's tablet ejection area.
2. Pull off the right-hand side panel door.
3. Turn the Hand Wheel manually for a few Turret rotations to ensure proper machine operation.
4. Pour the dry materials into the Hoppers.
5. Manually press a few tablets to avoid the chance of jamming the machine.
6. Reinsert the panel door.
7. Plug in the RTP 41® to an outlet and turn the isolator switch to power on the digital touch screen.
8. Choose the preferred language to go to the digital touch screen's menu.
9. Touch the Main button on the menu screen.

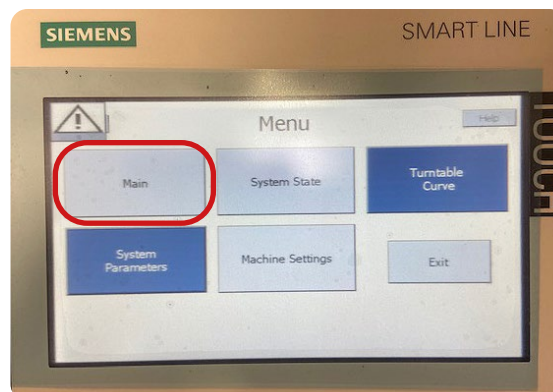

10. Press the Run button to begin machine operation.

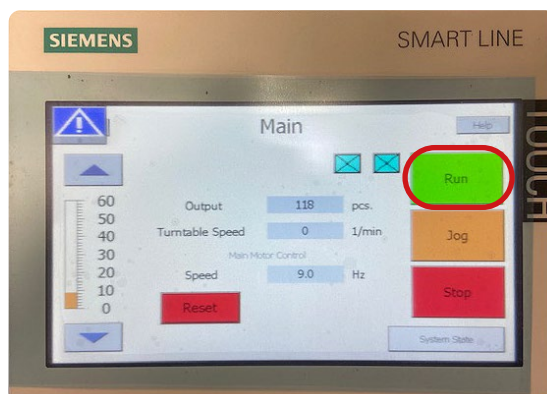

Settings and Adjustment

The RTP 41®'s settings can be adjusted. Tuning the machine can help with changing the tablets' characteristics.

Fill Depth

At times, a tablet will be too light or too heavy, and its weight must change. This simple adjustment determines the tablet's weight.

Tools and Materials Needed

- Raw material formulation
- Disposable latex/rubber gloves (for food grade products and to protect hands from grease)
- Hairnet and/or beard net (food grade products only)
- Sterile shoe covers (food grade products only)



WARNING: To prevent any potential personal injury, unplug the RTP 41® from the electrical outlet.

Instructions

Note: Wear latex/rubber gloves (and appropriate food grade attire if applicable) during this process.

1. Produce test tablets to determine how the machine should be adjusted.
2. Rotate the fill depth knob on the console to adjust.
 - 2.1 Note: To increase the weight rotate the knob counterclockwise (this lowers the Dosing Cam). To decrease the weight rotate the knob clockwise (this raises the Dosing Cam).
 - 2.2 Note: It may take several rotations of the knob to make the fill depth adjustment.



3. Plug in and run the machine to see if the adjustment is correct.
 - 3.1 Note: The tablets that come from the left side of the Ejection Chute are from the left fill depth knob's adjustment. The tablets that come from the right side are from the right fill depth knob's adjustment.

Fill Trays Height

The size of granules in your powder can affect how smoothly dry materials are moved through the Fill Trays, which can affect how much powder is wasted. Sometimes this requires the Fill Trays' height to be adjusted.

To watch a video of a Fill Tray calibration on a similar machine, go to <https://www.lfatabletpresses.com/rtp-9-adjusting-feed-frame>

Tools and Materials Needed

- Set of metric Allen keys
- Feeler gauge
- Wrench set
- Level
- Disposable latex/rubber gloves (for food grade products and to protect hands from grease)
- Hairnet and/or beard net (food grade products only)
- Sterile shoe covers (food grade products only)



WARNING: To prevent any potential personal injury, unplug the RTP 41® from the electrical outlet.

Instructions

Note: Wear latex/rubber gloves (and appropriate food grade attire if applicable) during this process.

1. Lift up both Hoppers from the top of the machine and set aside.



2. Raise each Perspex door.

3. Loosen both of the Fill Trays' Thumb Bolts with an Allen key.
4. Loosen both Fill Trays Scrapers and Take-Off Blades' screws with a crosshead screwdriver.

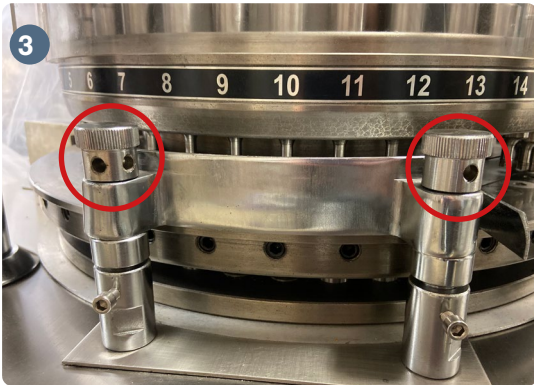

5. Run a feeler gauge between the Fill Trays and the Turret to determine the adjustment.
 - 5.1 Note: Start at 0.15 mm and raise appropriately if there is no powder waste/damage to the Fill Trays. If there is waste, lower it.
6. Adjust the Fill Trays Height Adjusters accordingly and tighten their bolts.
7. Resecure the Fill Trays Scrapers and Take-Off Blades' screws with a crosshead screwdriver.
 - 7.1 Note: Ensure the Take-Off Blades' distance from the Die Table is $\frac{1}{3}$ of the tablet's height.
8. Tighten the Fill Trays' Thumb Bolts with an Allen key.
9. Reinsert the Hoppers into the top of the machine.

Tablet Thickness

Sometimes you will need to adjust the tablets' thickness so that the pressure level relative to the fill is high, which results in creating a solid tablet.

Tools and Materials Needed

- Raw material formulation
- Disposable latex/rubber gloves (for food grade products and to protect hands from grease)
- Hairnet and/or beard net (food grade products only)
- Sterile shoe covers (food grade products only)



WARNING: To prevent any potential personal injury, unplug the RTP 41® from the electrical outlet.

Instructions

Note: Wear latex/rubber gloves (and appropriate food grade attire if applicable) during this process.

1. Produce test tablets to determine how the machine should be adjusted.
2. Rotate the left-hand knob on the console to change the punch pressure.
 - 2.1 Note: To make tablets thinner, rotate the knob counterclockwise (increase punch pressure). To make tablets thicker, rotate the knob clockwise (decrease punch pressure).
 - 2.2 Note: The pressure adjustment knob can be sensitive. Make adjustments in small increments.



3. Plug in and run the machine to see if the adjustment is correct.
 - 3.1 Note: The tablets that come from the left side of the Ejection Chute are from the left fill depth knob's adjustment. The tablets that come from the right side are from the right fill depth knob's adjustment.



CAUTION: If the punch pressure is increased too much, the machine will automatically cut off and show an error message on the display. Simply decrease the punch pressure to get the machine running again.

Turret Rotation Speed

Machine operation speed determines how fast the Turret rotates, which affects the speed of the Tooling going through the Upper and Lower Rollers. Adjusting the machine operation speed can affect output and dwell time.

To watch a video on dwell time go to <https://www.lfatabletpresses.com/dwell-time-in-tablet-compression>

Tools and Materials Needed

- Raw material formulation
- Disposable latex/rubber gloves (for food grade products and to protect hands from grease)
- Hairnet and/or beard net (food grade products only)
- Sterile shoe covers (food grade products only)

Instructions

Note: Wear latex/rubber gloves (and appropriate food grade attire if applicable) during this process.

1. Produce test tablets to determine how the machine should be adjusted.
2. Plug in the machine and turn the isolator switch to power on the digital touch screen.
3. Choose the preferred language to go to the digital touch screen's menu.
4. Touch the Main button on the menu screen.

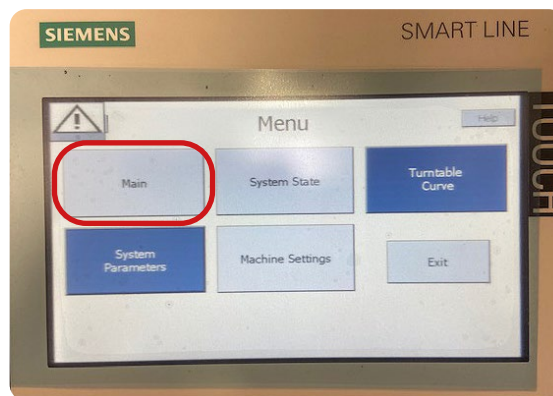

5. Press the arrows to increase or decrease the Turret rotation speed.

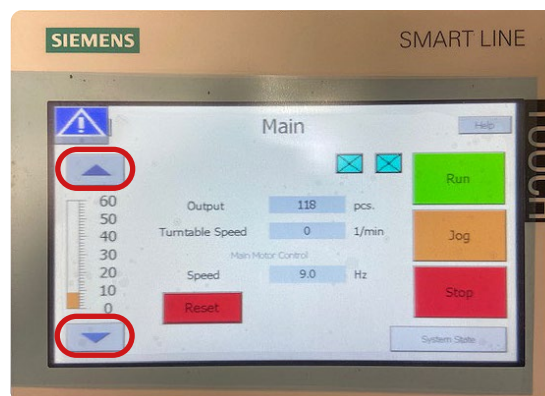

Maintenance

To ensure that the RTP 41® will have a long operational life, maintenance is essential. This section includes methods for replacing parts, troubleshooting solutions, and how often to grease and clean your machines to keep its performance optimal.

General Maintenance Prescriptions

- Use the maintenance checklist (found in the Appendix) before, during, and after machine operation.
- Make sure all grease points are maintained and regularly lubricated.
- Use an appropriate amount of lubricant. Excess grease can drip into the tablets as they are formed.
- Before reassembling the machine after cleaning, make sure that the parts are dried and oiled.
- Constantly check for any loose nuts and/or screws before, during, and after machine operation.
- If the machine is not used for more than a week, place the Tooling in an airtight container and cover in lubricant.

Lubrication

Regularly greasing your machine is vital to prolonging its operational life. Parts that are not greased properly can make the machine seize up and cause major problems later. LFA recommends maintaining a lubrication schedule for your RTP 41®, which can be found in this section.

Tools and Materials Needed

- Grease gun
- NLGI Grade 1 and Grade 2 grease
- SAE 90 or NSF approved equivalent
- SAE 10 oil
- Set of metric Allen keys with ball ends
- Disposable latex/rubber gloves (for food grade products and to protect hands from grease)
- Hairnet and/or beard net (food grade products only)
- Sterile shoe covers (food grade products only)



WARNING: To prevent any potential personal injury, unplug the RTP 41® from the electrical outlet.

Instructions

Note: Wear latex/rubber gloves (and appropriate food grade attire if applicable) during this process.

1. Raise each of the Perspex Casing's doors until they are held up by the pistons.

2. Remove the Upper Punches and Lower Punches.

2.1 For additional assistance, please refer to the Tooling replacement instructions on page 33.

3. Lubricate the heads of the Upper Punches and Lower Punches with NLGI Grade 1 grease.

4. Lubricate the barrels of the Upper Punches and Lower Punches with SAE 10 oil.



5. Apply SAE 10 or food grade equivalent to the wick to the Turret Drive Shaft's oil wells on top of the machine.



6. Lubricate the fill depth adjustment's grease nipple with NLGI Grade 2 grease.



7. Lubricate the pressure adjustment's grease nipple at the back of the machine with NLGI Grade 2 grease.



8. Lubricate the grease nipples on the Upper Roller Cams in the front and back of the machine.



9. Open the panel doors.



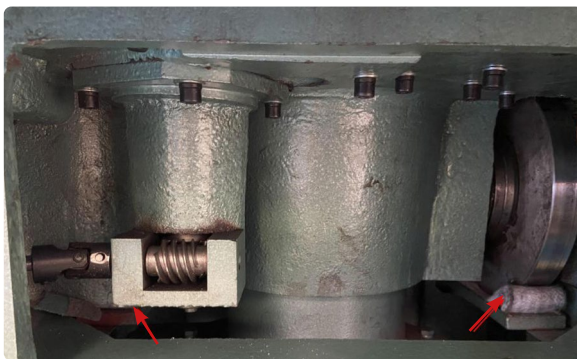

10. Lubricate the felt pads underneath the Lower Roller Cams with SAE 10 grease.

11. Inspect the Gearbox's eye glass and top off with WA 460 oil if needed.



Lubrication Schedule

LFA recommends the following RTP 41® parts to be lubricated according to the following frequency:

Part	Location	Image	Frequency	Type of Lubricant
Gearbox	On top of Gearbox through the shaft's bore		Visually inspect through the eye glass and top off when needed.	WA 460 Oil
Turret Drive Shaft Oil Wells	On top of the machine		Visually inspect and apply when dry.	SAE 90 or NSF Food Grade Equivalent
Fill Depth Adjustment	Grease nipple located on fill depth adjustment in front of the machine		Apply every 100 hours/ once per week.	NLGI Grade 2
Pressure Adjustment	Grease nipple located on pressure adjustment at the back of the machine		Apply every 100 hours/ once per week.	NLGI Grade 2
Tooling Heads	Heads of Upper Punches and Lower Punches		Inspect and apply when dry.	NLGI Grade 1
Tooling	Airtight container		Cover and store in oil after cleaning.	Mineral Oil
Tooling Barrels	The main shaft of the Upper Punches and Lower Punches		Every time Tooling is installed in the press.	SAE 10
Upper Roller Cams	Grease nipples on Upper Roller Cams in front and back of the machine		Apply every 100 hours/ once per week.	NLGI Grade 2

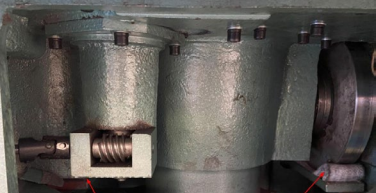
Part	Location	Image	Frequency	Type of Lubricant
Lower Roller Cams	Felt pads underneath the Lower Roller Cams		Visually inspect and apply when dry.	SAE 10

Dismantling for Repair and Replacement

Eventually due to wear and tear, some parts of the RTP 41[®] will need to be removed for repair and replacement. To prevent any delays in your tablet production, it is best practice to keep extra parts just in case.

To buy a RTP 41[®] part replacement, simply go to

<https://www.lfatabletpresses.com/products/pill-press-machine-spare-parts/rtp-41-parts>

Warranty

To access LFA's warranty policy, go to <https://www.lfatabletpresses.com/warranty>

If your part is eligible for warranty, have your part's serial number on hand and please contact LFA:

UK

Phone

+44 01869 250234

Email

support.uk@lfamachines.com

USA

Phone

+1 (682) 312-0034

Email

support.usa@lfamachines.com

Taiwan

Phone

+886 422031790

Email

support.asia@lfamachines.com



WARNING: To prevent any potential personal injury, ALWAYS unplug the RTP 41[®] from the electrical outlet when replacing parts.

Wear Parts and Causes of Damage

Wear Part	Cause of Damage
Tooling	The Tooling can become chipped or broken. Lead times for a new set of Tooling can take as long as 6-8 weeks, so LFA recommends having a spare set or two.
Fill Trays	On the RTP 41®, the Fill Trays is used to spread the powder over the Die Table and into the Die bores. There is a brass wear part located on the bottom of the Fill Trays. It protects the Turret/Die Table and the Tooling. If this part is damaged by a Die sitting above the Die Table, it is possible to refinish it using a flat stone, some oil, and 3000 grit sandpaper.
Fill Trays Scraper and Take-Off Blade	The Fill Trays Scraper is used to take off the excess powder from the Die Table after the Dosing Cam has forced out the powder. The Take-Off Blade is used to aid in tablet ejection. These parts can become damaged if a Die is protruding from the Die Table or if a Lower Punch jumps up from the Dosing Cam. To reduce waste, these parts will need to be replaced if damaged.
Ejection Cam	The Ejection Cam ejects the tablets at the correct moment in the Turret's cycle. This part is not able to be tuned and is fixed in place. Over time this part can wear, and the tablet's ejection point can get lower until they are not ejecting correctly from the Die bores. The three main causes of this are: 1) tight Lower Punches due to buildup of excess fines in powder, 2) high ejection forces that are caused by sticky powders clinging to the Die bore's wall, and 3) powder that mixes with oil/grease, which creates a sandpaper effect on the Ejection Cam.
Fill Cam	The Fill Cam pulls down the Lower Punches to fill the Die bores with powder. This part is built from brass and is designed to wear to protect the Tooling and the press. The main causes of a worn Fill Cam are: 1) tight Lower Punches due to buildup of excess fines in powder, 2) use of incorrect Tooling with the wrong head profile, and 3) powder that mixes with oil/grease, which creates a sandpaper effect on the Fill Cam.
Dosing Cam	The Dosing Cam is used to calibrate the press to produce the desired tablet weight. This is done by pushing excess powder out of the Die bore after it has been filled. The main causes of a worn Dosing Cam are: 1) Tight Lower Punches due to buildup of excess fines in powder, 2) use of incorrect Tooling with the wrong head profile, and 3) powder that mixes with oil/grease, which creates a sandpaper effect on the Dosing Cam.
Upper/Lower Roller Cams	The Roller Cams apply all the pressure onto the Tooling. If these become worn, it can cause damage to the tops of the Tooling and affect tablet hardness and consistency. This is predominantly caused by general wear and, in some cases, excess punch pressure being applied.

Tooling

If you want to change the shape and diameter of the tablet, or if any of the Upper Punches, Lower Punches, and/or Dies you currently have are damaged, it is necessary to change the Tooling. To watch a video of a similar machine's Tooling change, go to <https://www.lfatabletpresses.com/rtp10i-tooling-change>

To buy new Tooling from LFA, simply go to <https://www.lfatabletpresses.com/products/tablet-press-tooling>

Tools and Materials Needed

- Set of metric Allen keys with ball ends
- Wrench set
- Crosshead screwdriver
- New Tooling (Upper Punches, Dies, and Lower Punches)
- Toolkit (comes with machine)
- Lubricant (NSF approved for food grade products)
- Heavy rubber mallet
- Disposable latex/rubber gloves (for food grade products and to protect hands from grease)
- Hairnet and/or beard net (food grade products only)
- Sterile shoe covers (food grade products only)



WARNING: To prevent any potential personal injury, ALWAYS unplug the RTP 41[®] from the electrical outlet when replacing parts.

Instructions

Note: Wear latex/rubber gloves (and appropriate food grade attire if applicable) during this process.

Remove the Old Tooling

1. Lift up both Hoppers from the top of the machine and set aside.
2. Raise the Perspex doors until they are held up by the pistons.
3. Remove the Upper Punches' protective covering, which is located on the right side of the machine.

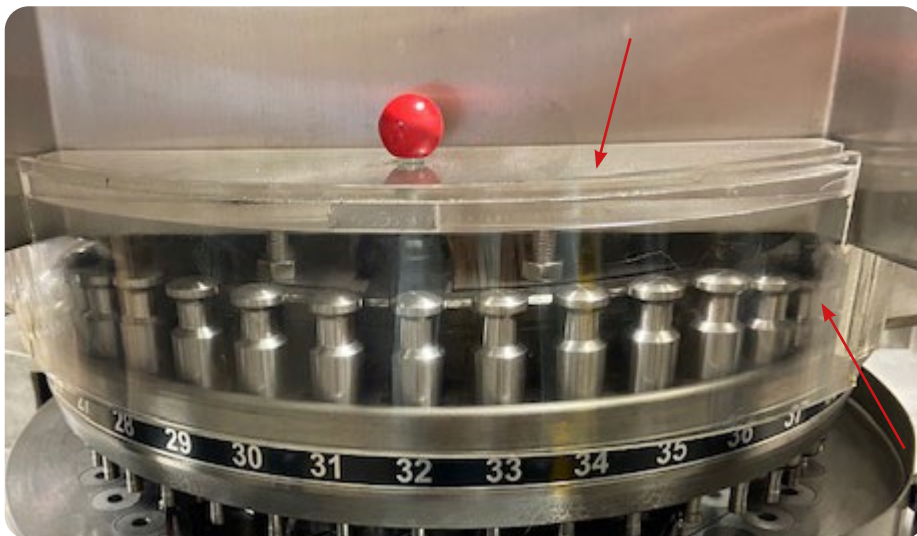

4. Loosen both Fill Trays' Thumb Bolts with an Allen key.

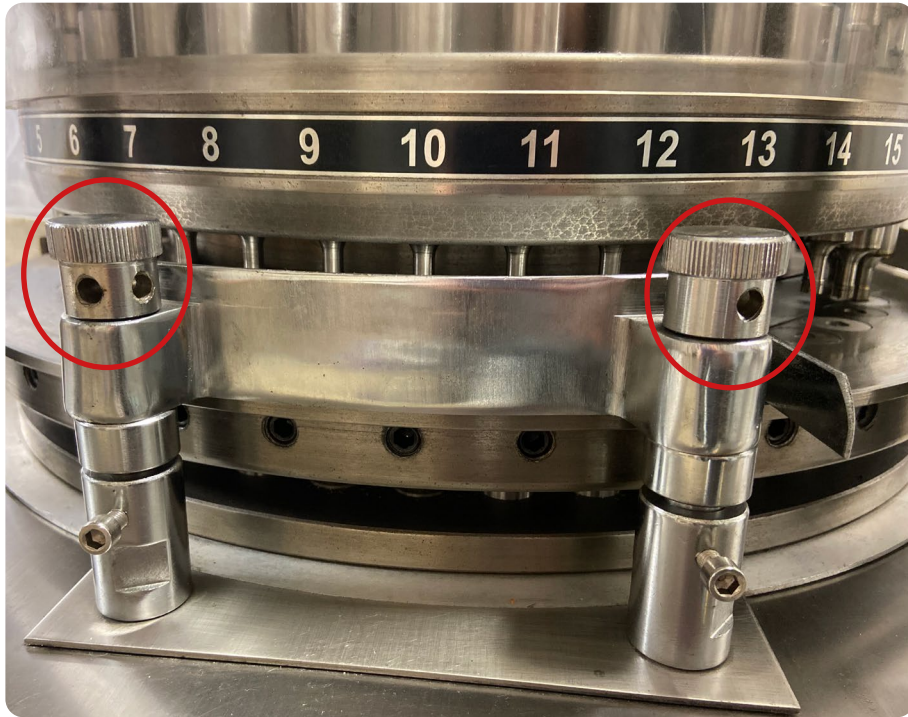

5. Remove both of the Fill Trays from the Turret.

6. Open the right side panel door.

7. Rotate the machine manually until an Upper Punch is centered with the Upper Tracking's key.



8. Pull the Upper Punch upwards to remove it from the Turret.
9. Repeat steps 6-7 until all Upper Punches are removed.
10. Find the Lower Punch Retaining Puck underneath the Lower Punches.
11. Using one hand underneath and the other above the Lower Punch Retaining Puck, push it up from underneath and guide it with the other hand above and out of the machine.
 - 11.1 Note: The Lower Punch Retaining Puck can become lost in the machine. Using both hands to guide it out will help prevent this.



12. Rotate the Hand Wheel until a Lower Punch is aligned with where the Lower Punch Retaining Puck was previously.
13. Gently pull on the Lower Punch's head through the hole.
 - 13.1 Note: Be sure to have a firm hold on the Lower Punch so that it does not fall and become damaged.
14. Repeat steps 12-13 until all Lower Punches are removed.

15. Rotate the Hand Wheel until a Die is aligned with where the Lower Punch Retaining Puck was previously.
16. Remove the Die's bolt with an Allen key.
17. Insert the Die Removal Bar up through the hole where the Lower Punch Retaining Puck was previously.

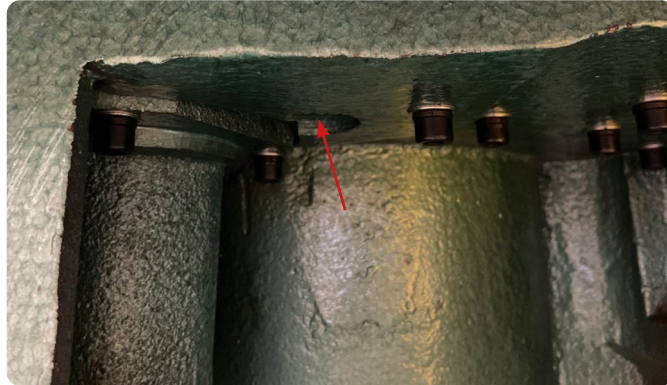

18. Tap the Die with the Die Removal Bar until it pops up from the Turret.
 - 18.1 Note: If Die is difficult to remove, tap the end of the Die Removal Bar with a rubber mallet.
19. Repeat steps 15-18 until all Dies are removed

Note: To help ensure that the Dies are inserted correctly, LFA recommends using an Insertion Ring. You can order the Die Seat Cleaner and Insertion Ring on our website at <https://www.lfatabletpresses.com/die-seat-cleaner-insertion-ring>



Replace the Tooling

20. Position the new Die on the Turret.
 - 20.1 Note: Place a bit of grease around the new Die's sides to make insertion easier.
21. Insert the Die Installation Bar through the Upper Punch's hole and over the new Die.
22. Tap the Die Installation Bar with a rubber mallet until the new Die is inserted into the Turret.
 - 22.1 Note: Make sure that the new Die is flush with the Turret.
23. Reinsert the Die's bolt in the Turret and tighten with an Allen key.
24. Rotate the Hand Wheel until the next new Die can be inserted.
25. Repeat steps 20-24 until all the new Dies are secured in the Turret.
26. Insert a new Lower Punch up through the Lower Punch Retaining Puck's hole and into the new Die's bore.
 - 26.1 Note: Lubricate the barrel of the Lower Punch.
27. Rotate the Hand Wheel until the next new Lower Punch can be inserted.
28. Repeat steps 26-27 until all the new Lower Punches are inserted into the Turret.
 - 28.1 Note: Manually turn the RTP 41® Turret for a couple of rotations to ensure that the new Lower Punches are situated correctly.
29. Reinsert the Lower Punch Retaining Puck with the beveled side facing up.
 - 29.1 Note: Make sure that the Lower Punch Retaining Puck is flat in the hole and not sticking up.

30. Insert a new Upper Punch through the top of the Turret.
30.1 Note: Lubricate the barrel of the Upper Punch.
31. Place the new Upper Punch's head on the Upper Tracking.
31.1 Note: Be sure that the new Upper Punch's head is above the Upper Tracking to prevent damage.

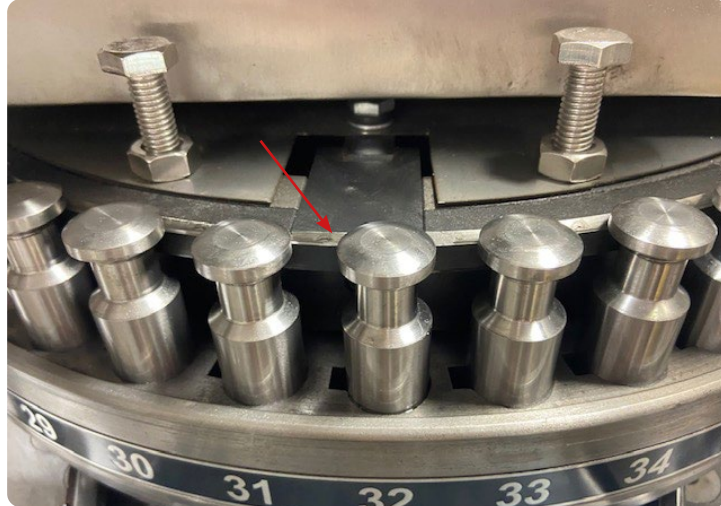

32. Rotate the Hand Wheel until the next new Upper Punch can be inserted.
33. Repeat steps 30-32 until all the new Upper Punches are inserted into the Turret.
33.1 Note: Manually turn the RTP 41® Turret for a couple of rotations to ensure that the new Upper Punches are situated correctly.
34. Place the Fill Trays back on each side of the machine and resecure them.
35. Place the right side panel door back on the machine.
36. Lower the Perspex doors.
37. Reinsert the Hoppers into the top of the machine.

Take-Off Blades and Fill Trays Scrapers

The Take-Off Blades and Scrapers are attached to each Fill Trays. They help keep the powder flowing into the Dies' bores and aid in tablet ejection.

Tools and Materials Needed

- Crosshead screwdriver
- Wrench set
- New Take-Off Blades and Fill Trays Scrapers parts
- Disposable latex/rubber gloves (for food grade products and to protect hands from grease)
- Hairnet and/or beard net (food grade products only)
- Sterile shoe covers (food grade products only)



WARNING: To prevent any potential personal injury, ALWAYS unplug the RTP 41[®] from the electrical outlet when replacing parts.

Instructions

Note: Wear latex/rubber gloves (and appropriate food grade attire if applicable) during this process.

Remove the Take-Off Blades and Fill Trays Scrapers

1. Lift up both Hoppers from the top of the machine and set aside.



2. Raise each Perspex door.

3. Loosen both of the Fill Trays' Thumb Bolts with an Allen key.

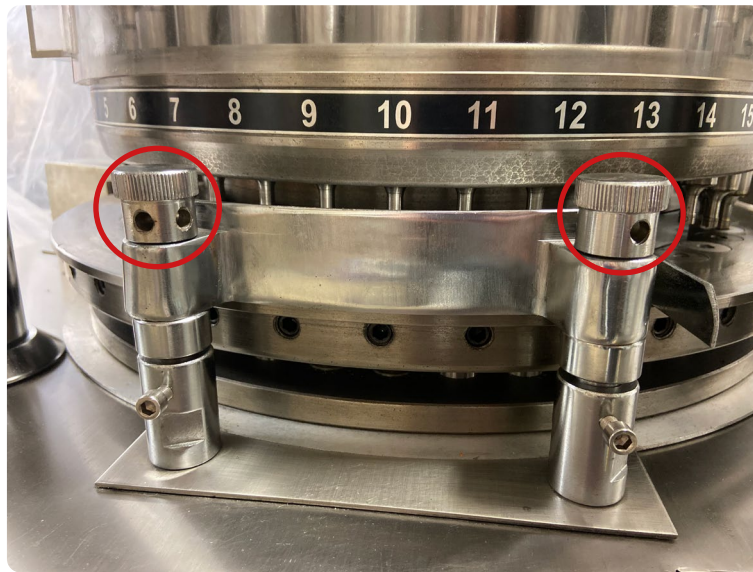

4. Remove both Fill Trays from the Turret.

5. Loosen both Fill Trays' Scrapers and Take-Off Blades' screws with a crosshead screwdriver.



6. Remove both Fill Trays' Scrapers and Take-Off Blades.

Replace the Take-Off Blades and Fill Trays Scrapers

7. Loosely secure the new Take-Off Blades and Scrapers on both Fill Trays with a crosshead screwdriver.

8. Place the Fill Trays with the new Take-Off Blades and Scrapers onto the Turret.

9. Tighten the Fill Trays' Thumb Bolts and secure with an Allen key.

10. Tighten the Fill Trays' Scrapers and Take-Off Blades with a crosshead screwdriver.

10.1 Note: It is important to make sure that the Fill Trays' Scraper Blades are firmly up against the Die Table of the Turret. To do this, push down on the top of the blades while tightening the screws that hold it in place. The Take-Off Blades needs to not be touching the Die Table and should be mounted approximately $\frac{1}{3}$ of the height of the tablet from the surface of the Die Table.

11. Lower each Perspex Door.

12. Reinsert the Hoppers into the top of the machine.

Fill Trays

The Fill Trays help channel the dry materials into the Die bores and also pushes the tablets out of the way and into the Ejection Chute. This part is designed to wear to avoid damaging the Tooling and/or Turret, so it may need to be replaced.

Tools and Materials Needed

- Set of metric Allen keys with ball ends
- Crosshead screwdriver
- New Fill Trays parts
- Disposable latex/rubber gloves (for food grade products and to protect hands from grease)
- Hairnet and/or beard net (food grade products only)
- Sterile shoe covers (food grade products only)



WARNING: To prevent any potential personal injury, ALWAYS unplug the RTP 41® from the electrical outlet when replacing parts.

Instructions

Note: Wear latex/rubber gloves (and appropriate food grade attire if applicable) during this process.

Remove the Fill Trays

1. Lift up both Hoppers from the top of the machine and set aside.



2. Raise each Perspex door.

3. Loosen both of the Fill Trays' Thumb Bolts with an Allen key.

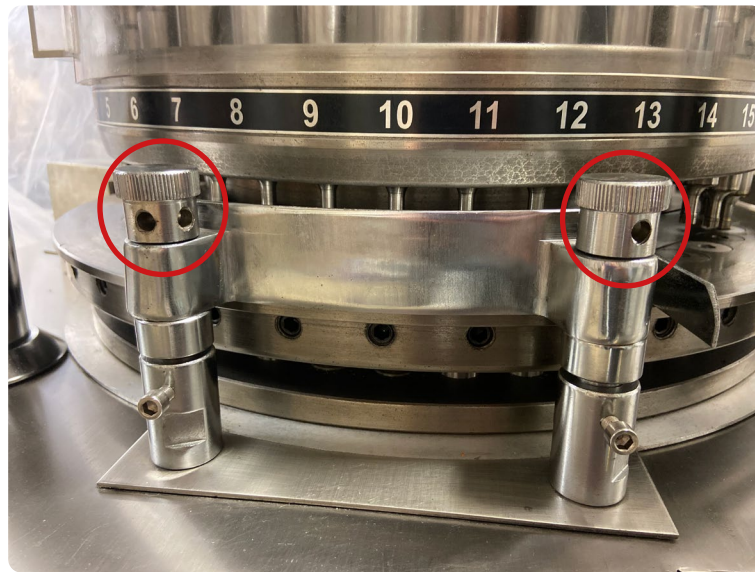

4. Remove both Fill Trays from the Turret.

5. Loosen both Fill Trays' Scrapers and Take-Off Blades' screws with a crosshead screwdriver.

6. Remove the both Fill Trays' Scrapers and Take-Off Blades.

Replace the Fill Trays

7. Loosely attach the Scrapers and Take-Off Blades onto the new Fill Trays with a crosshead screwdriver.

8. Position the Fill Trays onto the Turret and align them with the Fill Tray Height Adjusters' holes.

9. Screw in the Fill Tray Thumb Bolts through the Fill Trays and Fill Tray Height Adjusters.

9.1 Note: Please refer to the Fill Trays Height adjustment instructions on page 20 for calibration.

10. Tighten the Fill Trays' Scrapers and Take-Off Blades with a crosshead screwdriver.

10.1 Note: It is important to make sure that the Fill Trays' Scraper Blades are firmly up against the Die Table of the Turret. To do this, push down on the top of the blades while tightening the screws that hold it in place. The Take-Off Blades needs to not be touching the Die Table and should be mounted approximately 1/3 of the height of the tablet from the surface of the Die Table.

11. Lower each Perspex Door.

12. Reinsert the Hoppers into the top of the machine.

Lower Tracking

The Lower Tracking (the Fill Cam, Ejection Cam, and Dosing Cam) guides the Lower Punches' movement throughout the machine's operation.

To watch a video of what worn Lower Tracking cams look like on a similar machine, go to <https://www.lfatablepresses.com/rtp-9-inspecting-lower-cams>

Tools and Materials Needed

- Set of metric Allen keys with ball ends
- Crosshead screwdriver
- New Lower Tracking cams
- Disposable latex/rubber gloves (for food grade products and to protect hands from grease)
- Hairnet and/or beard net (food grade products only)
- Sterile shoe covers (food grade products only)



WARNING: To prevent any potential personal injury, ALWAYS unplug the RTP 41® from the electrical outlet when replacing parts.

Instructions

Note: Wear latex/rubber gloves (and appropriate food grade attire if applicable) during this process.

Remove the Lower Tracking

1. Raise each Perspex door until they are held up by the pistons.



2. Remove the coverings below the Perspex doors with a crosshead screwdriver.



3. Remove the left, right, and back side panel doors.
4. Loosen the cams' screws with an Allen key underneath the machine.

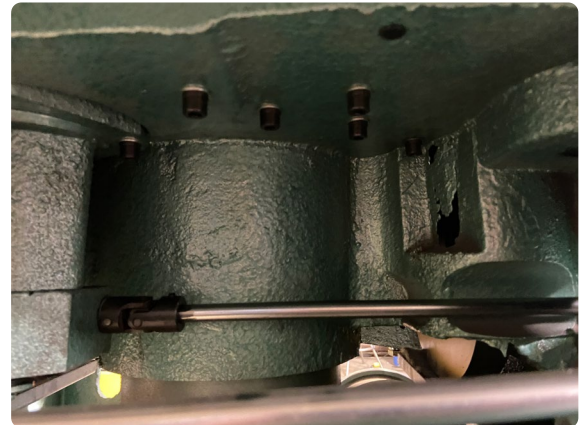

5. Remove the cams from the machine.

Replace the Lower Tracking

5. Position the new Fill Cam, Ejection Cam, and Dosing Cam over their screw holes.
6. Tighten the new cams' screws with an Allen key underneath the machine.
7. Reinsert the left, right, and backside panel doors.
8. Place back the coverings below the Perspex doors and secure them with a crosshead screwdriver.
9. Lower each Perspex door.

Upper Roller Cams

The Upper Roller Cams compress the Upper Punches to make tablets.

Watch a video to see what a worn Upper Roller Cam looks like at <https://www.lfatabletpresses.com/rtp-9-inspecting-roller-cams>

Tools and Materials Needed

- Set of metric wrenches
- Set of metric Allen keys with ball ends
- Crosshead screwdriver
- New Upper Roller Cams
- Disposable latex/rubber gloves (for food grade products and to protect hands from grease)
- Hairnet and/or beard net (food grade products only)
- Sterile shoe covers (food grade products only)



WARNING: To prevent any potential personal injury, ALWAYS unplug the RTP 41[®] from the electrical outlet when replacing parts.

Instructions

Note: Wear latex/rubber gloves (and appropriate food grade attire if applicable) during this process.

Remove the Upper Roller Cams

1. Lift up the Hoppers and set aside.
2. Loosen by hand the two screws on both of the Hoppers' holders and remove them.
3. Loosen the screws on the top covering of the machine.



4. Lift up the top covering from the machine and set aside.

5. Loosen the black nut with a wrench on one side of the machine.
6. Rotate the black screw all the way to the left.
7. Remove the split pin and pull out the black round pin.

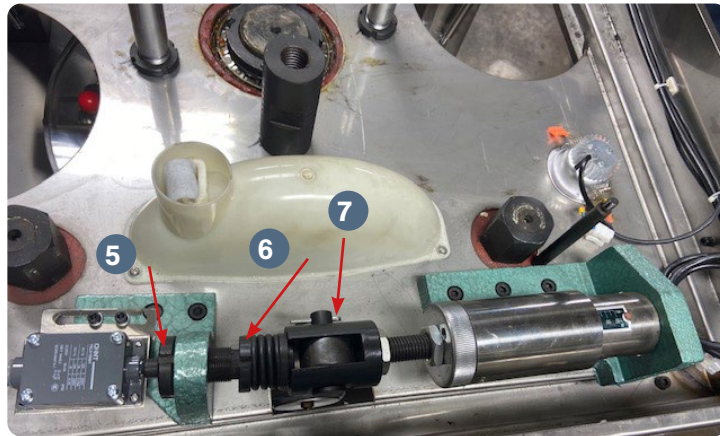

8. Loosen the screws that secure the Upper Roller Cam and remove it.
9. Repeat steps 5-8 for the Upper Roller Cam on the other side.

Replace the Upper Roller Cams

10. Insert the one of the new Upper Roller Cams into the machine.
11. Tighten the new Upper Roller Cam's screws to secure it.
12. Reinsert the black round pin and secure it with the split pin.
13. Rotate the black screw back all the way to the right.
14. Righten the black nut with a wrench.
15. Repeat steps 10-14 for the new Upper Roller Cam on the other side.
16. Place the top covering back on the machine.
17. Tighten the screws by hand on the top covering to secure it.
18. Tighten the screws on the Hoppers' holders.
19. Place the Hoppers back into the machine.

Troubleshooting

Sometimes unavoidable issues will occur while operating the RTP 41[®]. Fortunately, there are several methods to remedy these issues.

Common Machine/Part Issues

Symptom	Possible Cause	Possible Solution
Machine freezes or locks up	Grease point areas are dry.	Regularly oil and grease all the Grease Nipples and high friction areas.
	There is excess pressure.	Rotate the Pressure Knobs on the machine counterclockwise.
	There is caking of powder in the machine.	Take apart the Turret and Tooling and clean.
Knocking sounds coming from machine	There is excess pressure.	Rotate the Pressure Knobs on the machine counterclockwise.
	Parts may be loose.	Check the machine's parts and tighten as necessary.
	The Gearbox needs oil.	Check the Gearbox's oil gauge and lubricate as necessary.
Heavy resistance during production	The high friction areas are either unclean, locked, worn out, or not greased properly.	Apply grease to the Grease Nipple points and all high friction areas and/or clean the machine.
Excess machine vibration	The machine has no anti-vibration feet or they are worn.	Place new anti-vibration feet on the bottom of the machine.
	Parts may be loose.	Check the machine's parts and tighten as necessary.
Excess powder waste	The dry materials are moving too fast.	Lower the Hoppers' height to reduce powder flow.
	The Fill Trays are too high or unleveled.	Adjust the Fill Trays, Take-Off Blades, and Scrapers accordingly.
	There is a gap between the Turret and the Machine Base.	Apply NLGI Grade 4 grease to the gap between the Turret and Machine Base.

Symptom	Possible Cause	Possible Solution
Inability to compact materials to tablet form	The Fill Trays are blocked and not enough materials are flowing out.	Check the Fill Trays for a potential clog.
	There is not enough pressure.	Rotate the Pressure Knobs on the machine clockwise.
	The Tooling is damaged.	Remove and replace the Tooling (all Upper Punches, Lower Punches, and Dies).
	There are flowing issues with the mix.	If the machine is able to make tablets with LFA's Firmapress [®] , then the problem is your mix. Adjust your formulation. If still an issue, contact LFA for support.
Powder sticks to the Upper Punches	There is damage to the Tooling or the Tooling's design is causing sticking.	Remove and replace the Tooling (all Upper Punches, Lower Punches, and Dies).
	There are issues with the mix.	Adjust your formulation. If still an issue, contact LFA for support.
Powder sticks to the Lower Punches	There are issues with the mix.	Adjust your formulation. If still an issue, contact LFA for support.

Common Tablet Issues

Symptom	Possible Cause	Possible Solution
Double tablets	Previous tablet did not eject correctly.	Remove the double tablet manually from the Die bore.
	Excess granular materials were placed in the Die, which prevented the ejection of the existing tablet.	Clean the Tooling to remove any excess granular materials and make sure that it is clean and completely dry.
Cracked or broken tablets	There are problems with the formulation of the granules and ingredients.	If the machine is able to make tablets with LFA's Firmapress®, then the problem is your mix. Adjust your formulation. If still an issue, contact LFA for support.
	The Fill Trays are not feeding enough material to be pressed in tablet form.	Adjust the Fill Trays, Take-Off Blades, and Scrapers accordingly.
	There is excess pressure.	Please read our article on Capping at https://www.lfatabletpresses.com/articles/tablet-capping
Inconsistent Tablet Weight	There are flowing issues with the mix.	If the machine is able to make tablets with LFA's Firmapress®, then the problem is your mix. Adjust your formulation. If still an issue, contact LFA for support.
Soft tablets	There is too little punch pressure.	Rotate the Pressure Knob on the machine counterclockwise.
	There are flowing issues with the mix.	If the machine is able to make tablets with LFA's Firmapress®, then the problem is your mix. Adjust your formulation. If still an issue, contact LFA for support.
Uneven tablets	The Tooling is worn out.	Check the ingredients of your formula before you replace the Tooling.
Broken tablets during ejection	The Ejection Cam is dirty.	Inspect Ejection Cam and clean if necessary.
	The Ejection Cam is worn.	Replace the Ejection Cam.

De-Jamming the RTP 41[®]

A reason why a RTP 41[®] might jam is because the fill depth is set too low and the pressure is set too high. At its highest punch pressure force, the machine will automatically cut off.



WARNING: To prevent any potential personal injury, ALWAYS unplug the RTP 41[®] before de-jamming it.

Tools and Materials Needed

- Disposable latex/rubber gloves (for food grade products and to protect hands from grease)
- Hairnet and/or beard net (food grade products only)
- Sterile shoe covers (food grade products only)

Instructions

Note: Wear latex/rubber gloves (and appropriate food grade attire if applicable) during this process.

Method: Lower the Punch Pressure

1. Press the Emergency Stop button.
2. Rotate the Pressure Knobs on the console counterclockwise to their limits.
3. Rotate the Fill Depth knobs on the console counterclockwise to their limits.
4. Open the right side panel door.
5. Turn the Hand Wheel clockwise until the machine turns over.



Cleaning

During the RTP 41®'s operation, excess powder will find its way into parts of the machine, particularly in the Tooling and Fill Trays. It is important to clean the RTP 41® thoroughly to prevent rusting and cross contamination.

LFA recommends that the machine be cleaned after each operation.

Tools and Materials Needed

- Container for excess powder
- Cleaning brush
- Bagless vacuum
- Long wire pipe cleaner
- Toothbrush
- Cleaner (e.g. Member's Mark Commercial Lemon Fresh Disinfectant)
- Sanitizer (e.g. Member's Mark Commercial Sanitizer)
- Set of metric Allen keys with ball ends
- Crosshead screwdriver
- Flathead screwdriver
- Die Installation/Removal Bar from RTP 41® Toolkit
- Disposable latex/rubber gloves
- Bowl of warm soapy water (nothing abrasive)
- Clean cloths
- Potable water
- Hairnet and/or beard net (food grade products only)
- Sterile shoe covers (food grade products only)



WARNING: To prevent any potential personal injury, ALWAYS unplug the RTP 41® from the electrical outlet when replacing parts.

Instructions

Note: Wear latex/rubber gloves (and appropriate food grade attire if applicable) during this process.

Remove Parts

1. Remove the Hoppers, the Fill Trays and their Scrapers and Take-Off Blades, and the Tooling.
 - 1.1 Note: Please refer to the replace Tooling instructions on page 30 for further information.
2. Remove all the side panel doors.
3. Use a brush to bring powder debris out from hard-to-reach places.
4. Vacuum the top section of the RTP 41®.
5. Vacuum the entire areas enclosed by the side panel doors.
 - 5.1 Note: Be sure to vacuum all corners of the RTP 41® base.

Note: Before washing the Turret, LFA recommends using our Die Seat Cleaner. You can order the Die Seat Cleaner and Insertion Ring on our website at <https://www.lfatabletpresses.com/die-seat-cleaner-insertion-ring>



Clean the Parts

6. Take one of the parts removed by the machine and bring it to the bowl of soapy water.
 - 6.1 Note: To ensure that all dirt and debris are removed, wash one part at a time.
7. Take a clean cloth and carefully wash the part thoroughly.
8. Dry part immediately after it is cleaned and rinsed.
9. Sanitize part with a clean cloth.
10. Lubricate part.
11. Repeat steps 6-10 for each remaining part until they are all clean.

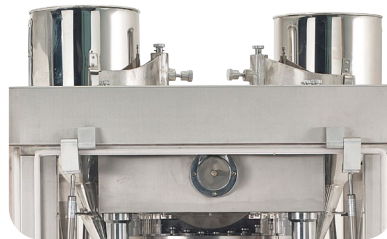

Clean the Base

12. Spray the RTP 41[®] base with the cleaner, particularly in the Tooling's location.
13. Rinse the cleaner off with potable water and dry the base immediately after.
 - 13.1 Note: Ensure that the machine's base is completely dry.
14. Sanitize the RTP 41[®] base with a clean cloth.
15. Lubricate the RTP 41[®] base.

Cleaning Schedule Matrix

Part	Frequency							
	After installing machine	After every use	Before every use	In between products that present a cross contamination risk	Weekly	Monthly	Before placing in storage	After removing from storage
Tooling	Remove from machine	Remove from machine	Install into machine	Remove from machine	N/A	N/A	Remove from machine	Install into machine
Hopper	Remove from machine	Remove from machine	Install into machine	Remove from machine	N/A	N/A	Remove from machine	Install into machine
Perspex Casing	Clean on machine	Clean on machine	Clean on machine	Clean on machine	N/A	N/A	Clean on machine	Clean on machine
Turret and surrounding area	Clean in machine	Clean in machine	Clean in machine	Clean in machine	N/A	N/A	Clean in machine	Clean in machine
Fill Trays and surrounding area	Remove from machine	Remove from machine	Install into machine	Remove from machine	N/A	N/A	Remove from machine	Remove from machine
Upper Cam Housing (Upper Roller Cams)	Clean in machine	Clean in machine	Clean in machine	Clean in machine	Clean in machine	Remove from machine	Clean in machine	Clean in machine
Upper Tracking	Clean in machine	Clean in machine	Clean in machine	Clean in machine	Clean in machine	Remove from machine	Clean in machine	Clean in machine
Lower Cam Housing (Lower Roller Cams)	Clean in machine	Clean in machine	Clean in machine	Clean in machine	Clean in machine	Remove from machine	Clean in machine	Clean in machine
Lower Tracking	Remove from machine	Clean in machine	Clean in machine	Clean in machine	Clean in machine	Remove from machine	Clean in machine	Remove from machine
Motor	Clean in machine	Clean in machine	Clean in machine	Clean in machine	Clean in machine	Remove from machine	Clean in machine	Clean in machine
Gearbox	Clean in machine	Clean in machine	Clean in machine	Clean in machine	Clean in machine	Remove from machine	Clean in machine	Clean in machine
Drive Belt Pulleys	Clean in machine	Clean in machine	Clean in machine	Clean in machine	Clean in machine	Remove from machine	Clean in machine	Clean in machine
Exterior	Clean on machine	Clean on machine	Clean on machine	Clean on machine	Clean on machine	Remove from machine	Clean on machine	Clean on machine
Ejection Tray	Remove from machine	Remove from machine	Install into machine	Remove from machine	N/A	N/A	Remove from machine	Remove from machine

Cleaning Level Key	
Level 1 - Remove powder	
Level 2 - Dry clean with cloth	
Level 3 - Dry clean and re-lubricate if specified in lubrication schedule	
Level 4 - Wet clean and re-lubricate if specified in lubrication schedule	
Remove from machine - Take part out of machine and clean if required. Store it correctly or install back into machine.	
Install into machine - Install part into the machine and make sure that it has been cleaned. If needed, lubricate to the level required.	
Clean on/in machine - Clean the part while in the machine and do not remove it. Make sure that all contact surfaces are clean to the level required.	

This cleaning matrix is intended as a guide only and is not an exhaustive list. All cleaning schedules will need to be adapted to the industry and product, following industry regulations and the material safety data sheets that come with specific products. Please check with your Food Safety Manager/Department, Quality Control Manager/Department, or other relevant internal departments at your company before using.

Storing the RTP 41®

After its thorough cleaning, the RTP 41® needs to be stored in the proper conditions. It is important to store it in an environment in which the machine is safe from rusting. The RTP 41®'s high traction areas and the Tooling need to be lubricated separately before you store them.

Tools and Materials Needed

- Plastic wrapping to cover machine
- Airtight container for Upper Punches, Lower Punches, and Dies (if in storage for more than a week)
- Grease gun
- Lubricant/grease (NSF approved lubricant if machine has a high chance of contact with the food or drug product)
- Disposable latex/rubber gloves (for food grade products and to protect hands from lubricant)
- Hairnet and/or beard net (food grade products only)
- Sterile shoe covers (food grade products only)

Instructions

Note: Wear latex/rubber gloves (and appropriate food grade attire if applicable) during this process.

Lubricating the Tooling

If you are not using the machine for more than a week, store the Tooling in an airtight container (like the one pictured below) and cover it with lubricant to prevent rust formation. If not, simply lubricate each part of the Tooling, particularly the heads and barrels of the Upper and Lower Punches, and reinsert it back into the machine.



LFA's Rotary Tooling Case provides storage and is perfect for transport and protection. Order at <https://www.lfatabletpresses.com/rotary-tooling-case>

Lubricating the Main Worm Gear

The Main Worm Gear is mounted above the Motor in the lower section of the tablet press. Visually inspect to see the oil level. Apply WA 460 Oil whenever it is dry.

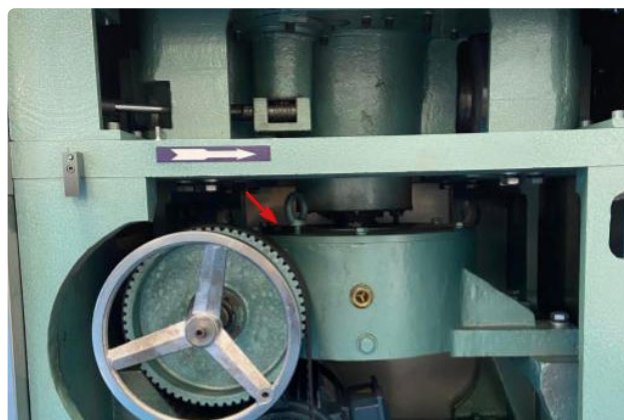

Lubricating the Grease Points and High-Traction Parts

1. Apply SAE 10 to the Turret Drive Shaft Oil Wells on top of the machine.



2. Apply NLGI Grade 2 grease to the fill depth adjustment's grease nipple.

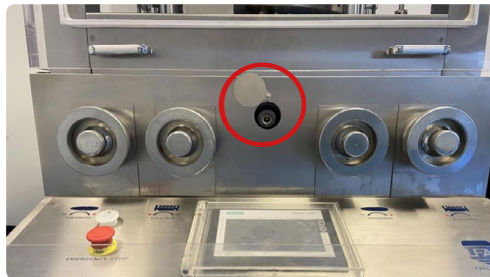

3. Apply NLGI Grade 2 grease to the pressure adjustment's grease nipple.



4. Apply NLGI Grade 2 grease to the both of the Upper Roller Cams' grease nipples.

5. Apply SAE 10 to the felt pads underneath the Lower Roller Cams.

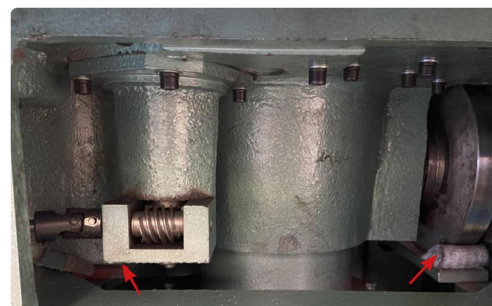
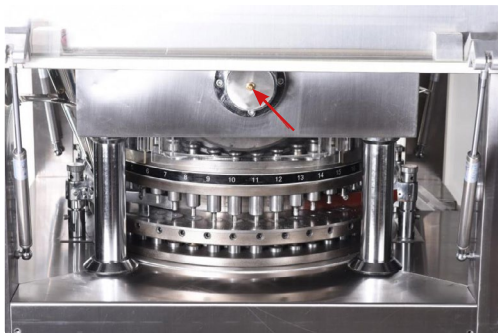

Environmental Conditions

It is important that the environment in which you store the RTP 41® has the appropriate temperature and relative humidity levels. These two environmental factors can potentially cause the machine to rust and/or cause the tablets to have a lower quality. The table below shows the acceptable temperature and relative humidity levels:

Machine	Temperature		Humidity
	°C	°F	
RTP 41®	18-24	64-75	45-65% RH

Appendix

Glossary

Term	Definition
API/Active Pharmaceutical Ingredient	Any substance or mixture of substances used that is an active ingredient in the drug product.
Binding agent	See excipient.
Die	The part of the Tooling that makes up the hole in which the powder is compressed and shaped into a tablet.
Die bore	The cavity inside the middle of the Die.
Die face	The very top flat surface of the Die.
Ejection height	The height at which the Lower Punch is lifted to for a tablet's ejection from the machine.
Excipient	An inactive substance that serves as the vehicle or medium for a drug or other API.
Fill depth	The amount of space that the powder can flow into in the Die.
Formulation	Powder mix of the excipient and the API that is compressed to make tablets.
Granular material	See Formulation.
Kilonewton (kN)	The force to accelerate a mass of 1 kg at a constant 1 m per second. The RTP range's pressure is measured in this unit.
Punches	The Upper Punch and Lower Punch have concave endings in the shape of the desired tablet. When the punches meet, they compress the powder between.
Punch pressure	The adjustable amount of force that is used to press tablets.
RTP®	LFA trademarked term for rotary tablet press.
Tooling	Enables a tablet press to form tablets. It consists of Dies, Upper Punches, and Lower Punches.

Description of RTP 41® Parts

Tooling

The Tooling consists of the Dies, the Upper Punches, and the Lower Punches. They all work as a set and compress the powder into tablets.

Order at <https://www.lfatabletpresses.com/products/tablet-press-tooling>



Upper Roller Cam

The Upper Roller Cam determines the Upper Punch's position within the Die bore during compression. Order at <https://www.lfatabletpresses.com/upper-roller-cam-rtp-41>

Lower Tracking Kit

The Lower Tracking Kit consists of three components: the Ejection Cam, the Fill Cam, and the Dosing Cam. These all guide and move the Lower Punches. Order at <https://www.lfatabletpresses.com/lower-tracking-kit-rtp-41>

Ejection Cam

The Ejection Cam pushes the Lower Punches up through the Die bores to eject the tablets from the press. Order at <https://www.lfatabletpresses.com/ejection-cam-rtp-41>

Take-Off Blades and Fill Trays Scrapers

The Fill Trays Scrapers (non-metal) help keep the powder flowing into the Dies' bores, and the Take-Off Blades (metal) aids in tablet ejection. Order at <https://www.lfatabletpresses.com/fill-tray-scraper-rtp-41> and <https://www.lfatabletpresses.com/take-off-blade-rtp-41>

Lower Roller Cam

The Lower Roller Cam determines the Lower Punch's position within the Die bore during compression. Order at <https://www.lfatabletpresses.com/lower-roller-cam-rtp-41>

Fill Cam

The Fill Cam pulls down the Lower Punches into the Die bores, which allows powder to enter. Order at <https://www.lfatabletpresses.com/fill-cam-rtp-41>

Dosing Cam

The Dosing Cam adjusts the weight of the tablet that results from powder compression. Order at <https://www.lfatabletpresses.com/dosing-cam-rtp-41>

Upper Tracking

The Upper Tracking holds the Upper Punches and guides their movement through the Turret. Order at <https://www.lfatabletpresses.com/upper-tracking-rtp-41>

Oil Well Pads

The Turret Drive Shaft is lubricated by oil wells located on the top of the machine. Inside the wells are felt pads that will need to be replaced periodically. Order at <https://www.lfatabletpresses.com/oil-well-pads-rtp-41>



Center Die Grub Screw (10)

Each of the Dies is secured to the Turret with a grub screw, which can be damaged or lost. Order at <https://www.lfatabletpresses.com/center-die-grub-nut-rtp-41>

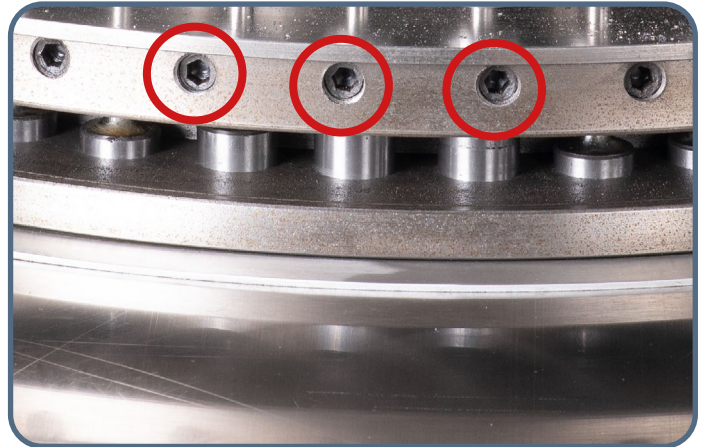

Material of Contact Parts

Contact Part	Material
Turret	Cast iron 250
Ejection Tray	SUS304
Hoppers	SUS304
Tooling (Upper Punches, Lower Punches, and Dies)	User specified
Fill Trays	Tin bronze QSN-6-3
Fill Trays Scrapers and Take-Off Blades	Bakelite and copper coat Zn

Technical Specifications

Model	RTP 41 (Standard)	RTP 41 (Euro)	RTP 23 (Euro)
Tooling specification	RTP Tooling	Euro BB Tooling	Euro D Tooling
Number of Dies	41	41	23
Production capacity	182,040/hr	182,040/hr	102,000
Max diameter of tablet	12 mm	13 mm	25 mm
Max fill depth	15 mm	15 mm	15 mm
Thickness of tablet	6 mm	6 mm	6 mm
Max pressure	80 kN	80 kN	80 kN
Number of filling stations	2	2	2
Double layered tablet	On request	On request	On request
Power USA	220 V 3 phase 5.5 kW 60 Hz	220 V 3 phase 5.5 kW 60 Hz	220 V 3 phase 5.5 kW 60 Hz
Power UK	440 V 3 phase 5.5 kW 50 Hz	440 V 3 phase 5.5 kW 50 Hz	440 V 3 phase 5.5 kW 50 Hz
Amps	32	32	32
Overall size (mm)	1670 x 950 x 1230	1670 x 950 x 1230	1670 x 950 x 1230
Dimensions with suggested working clearance (mm)	2570 x 1850 x 2130	2570 x 1850 x 2130	2570 x 1850 x 2130
Weight	1676.5 kg (3,696 lbs)	1676.5 kg (3,696 lbs)	1676.5 kg (3,696 lbs)
Floor loading (static)	2.43 kN/m ²	2.43 kN/m ² .	2.43 kN/m ² .
Max decibels	92.3 dB (with dust vacuum)	92.3 dB (with dust vacuum)	92.3 dB (with dust vacuum)
Turret Speed	14-37 r/min	14-37 r/min	14-37 r/min

Maintenance Checklist

Before Operation	
<input type="checkbox"/>	Visually inspect the tablet press and the parts.
<input type="checkbox"/>	Ensure all locking nuts are tight.
<input type="checkbox"/>	Visually inspect grease nipples and regrease where necessary.
<input type="checkbox"/>	Manually rotate the machine without powders to ensure that it is not jammed
<input type="checkbox"/>	Ensure Perspex doors securely enclose the upper portion of machine.
<input type="checkbox"/>	Visually inspect electrical wires for any damage.
During Operation	
<input type="checkbox"/>	Tune the tablet press until the tablet size and weight are correct.
<input type="checkbox"/>	Listen for irregular knocking or clicking sounds. If heard, stop operation, release the pressure by rotating the Pressure Knobs on the machine counterclockwise a few times, and lubricate the machine.
<input type="checkbox"/>	Watch for buildup of powder in front of the Fill Trays. If occurring, either (a) make mix more granular, (b) check the Fill Trays for damage, (c) clear the buildup, or (d) adjust the Fill Trays.
<input type="checkbox"/>	Occasionally check the Motor's temperature. If it starts to overheat, turn off the machine, let it cool down, and grease it to ensure smooth operation.
<input type="checkbox"/>	Ensure that the Hoppers do not run out of powder.
<input type="checkbox"/>	Weigh five or ten sample tablets to ensure the desired weights, tablet height, and hardness are being met.
<input type="checkbox"/>	Check to see that the Emergency Stop properly works.
After Operation	
<input type="checkbox"/>	Unplug machine and remove all excess powder with a bagless vacuum.
<input type="checkbox"/>	Remove the Hoppers, Fill Trays, and Tooling and clean the inside of the tablet press.
<input type="checkbox"/>	Wipe down the other surfaces with a damp cloth.
<input type="checkbox"/>	Apply a layer of NSF approved grease to the entire tablet press.
<input type="checkbox"/>	Lubricate all grease nipples.
<input type="checkbox"/>	Store Tooling in an airtight box with a small amount of grease.

Diagrams

RTP 41® Dimensions

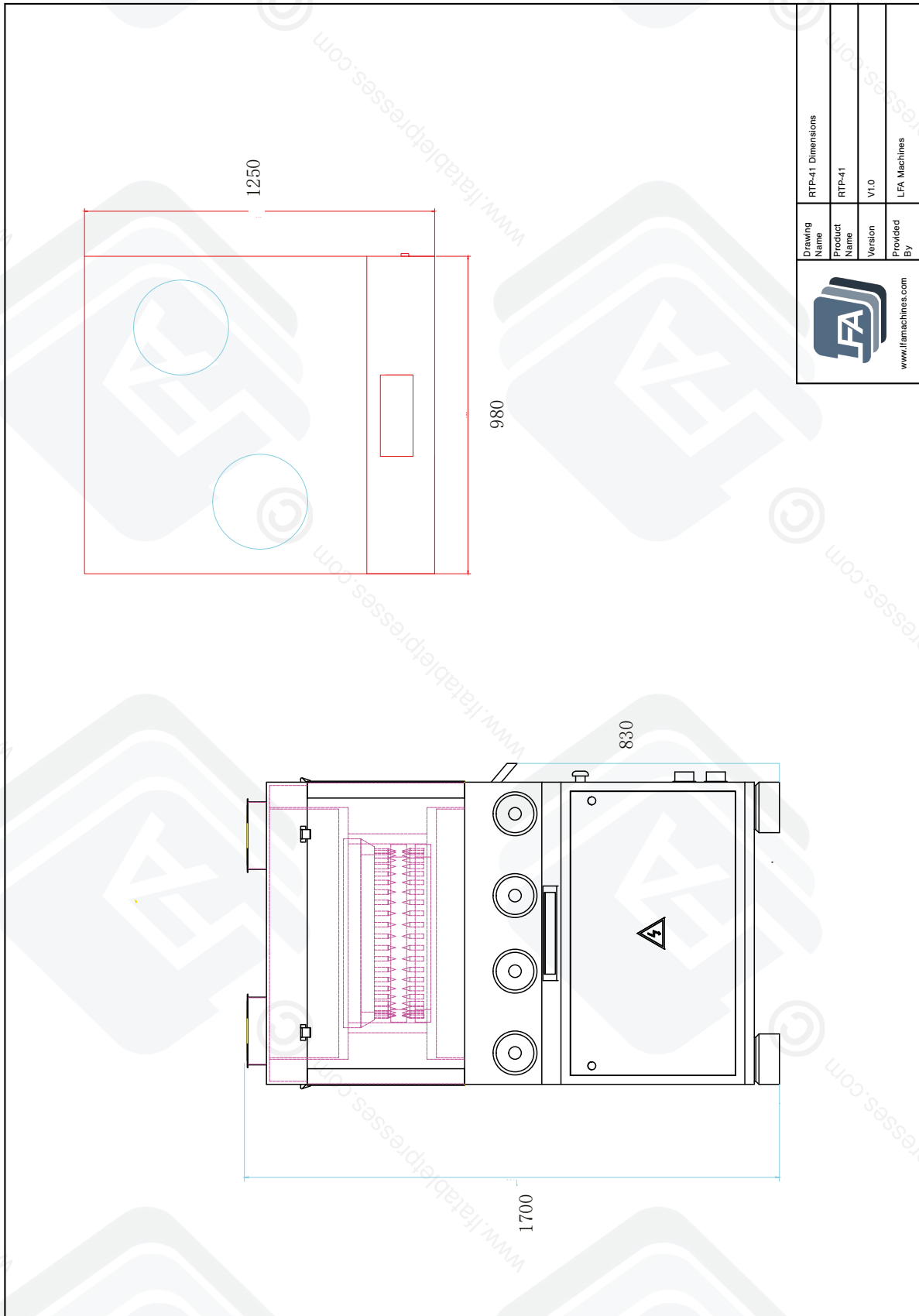

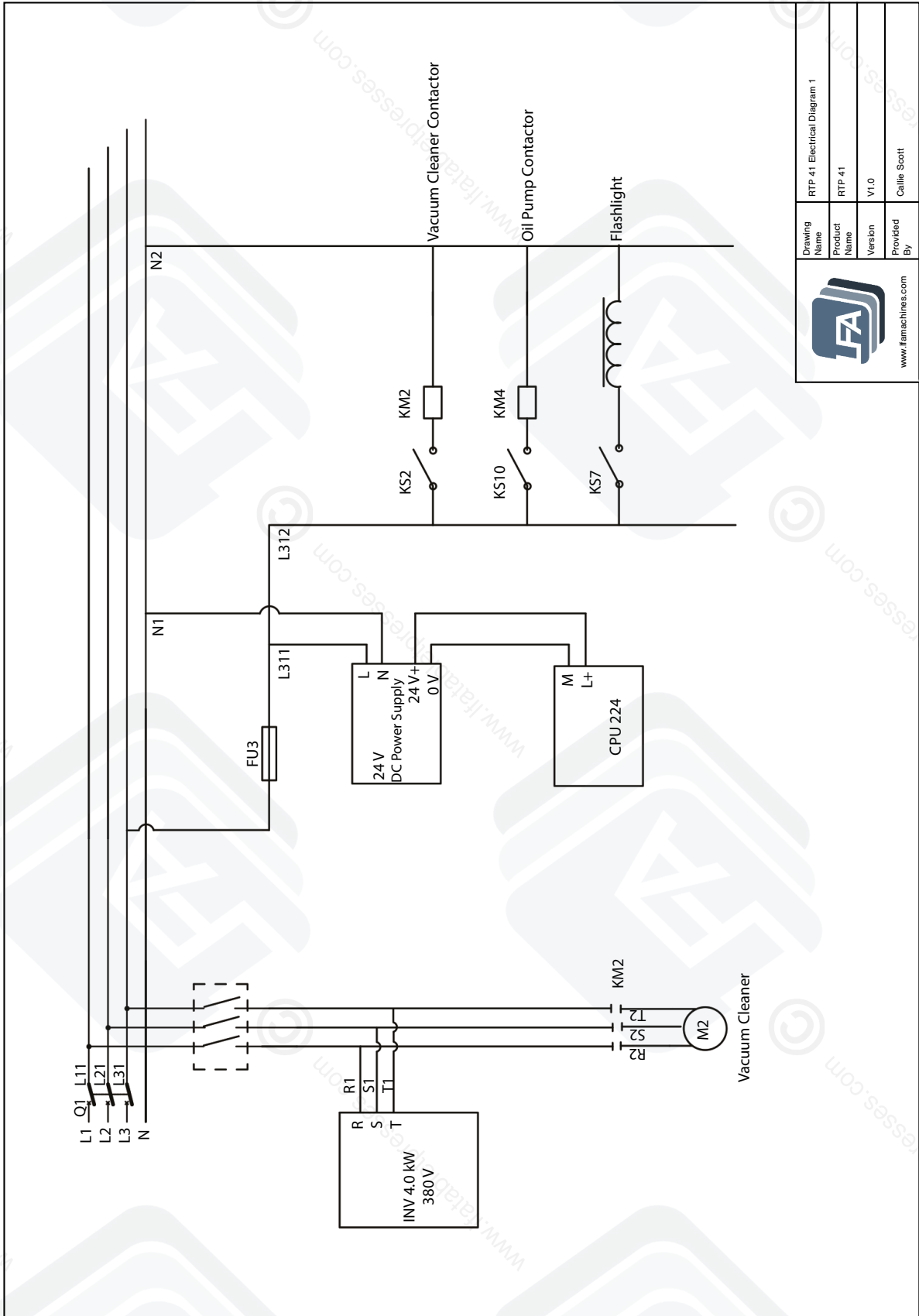

RTP 41® Electrical Diagram 1

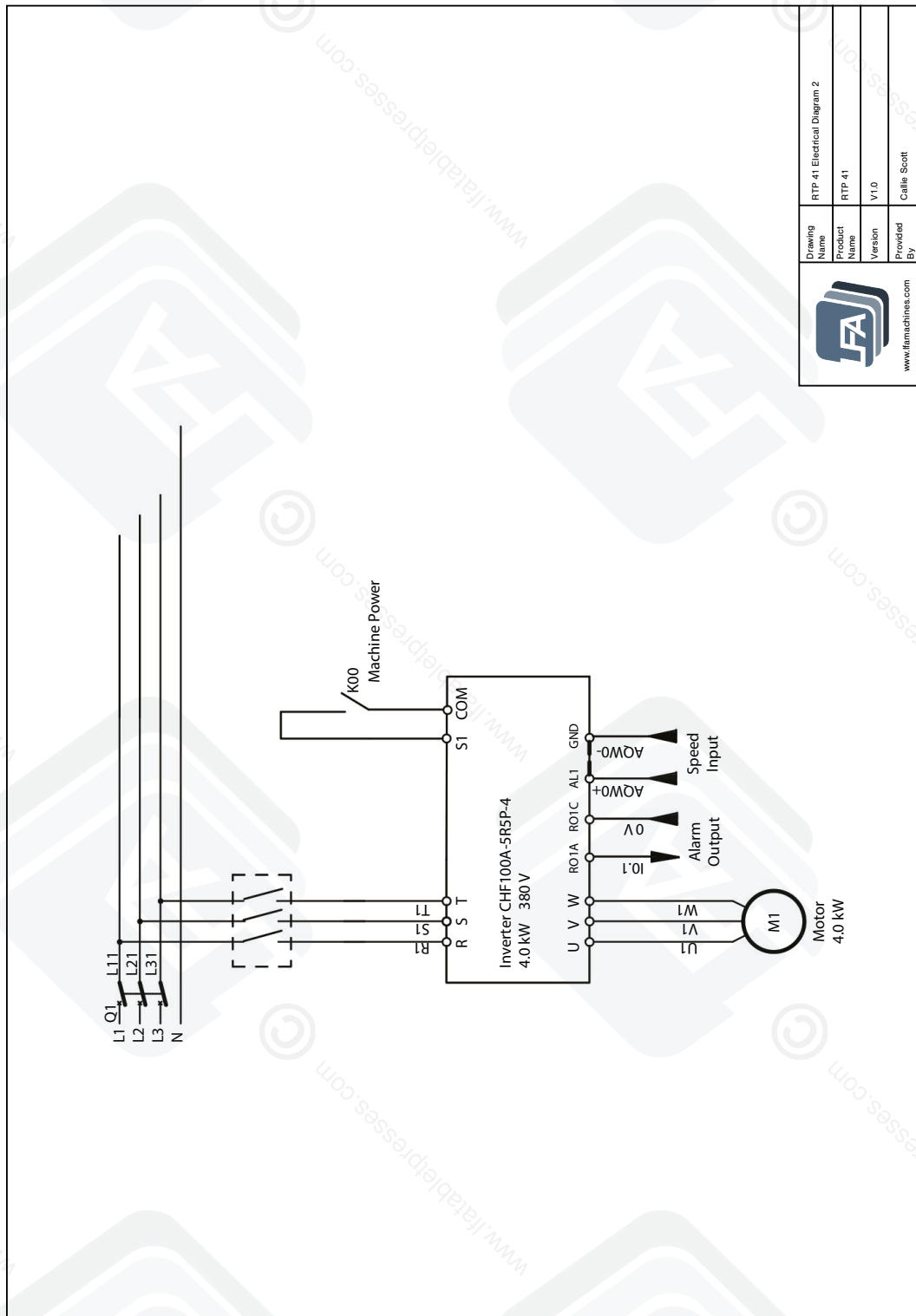

 www.ifa-machines.com		Drawing Name	RTP 41 Electrical Diagram 1
Product Name	RTP 41	Version	V1.0
Provided By	Caille Scott		

RTP 41® Electrical Diagram 2



 www.jfamachines.com	Drawing Name	RTP-41 Electrical Diagram 2
	Product Name	RTP-41
	Version	V1.0
	Provided By	Calle Scott

RTP 41® Electrical Diagram 3

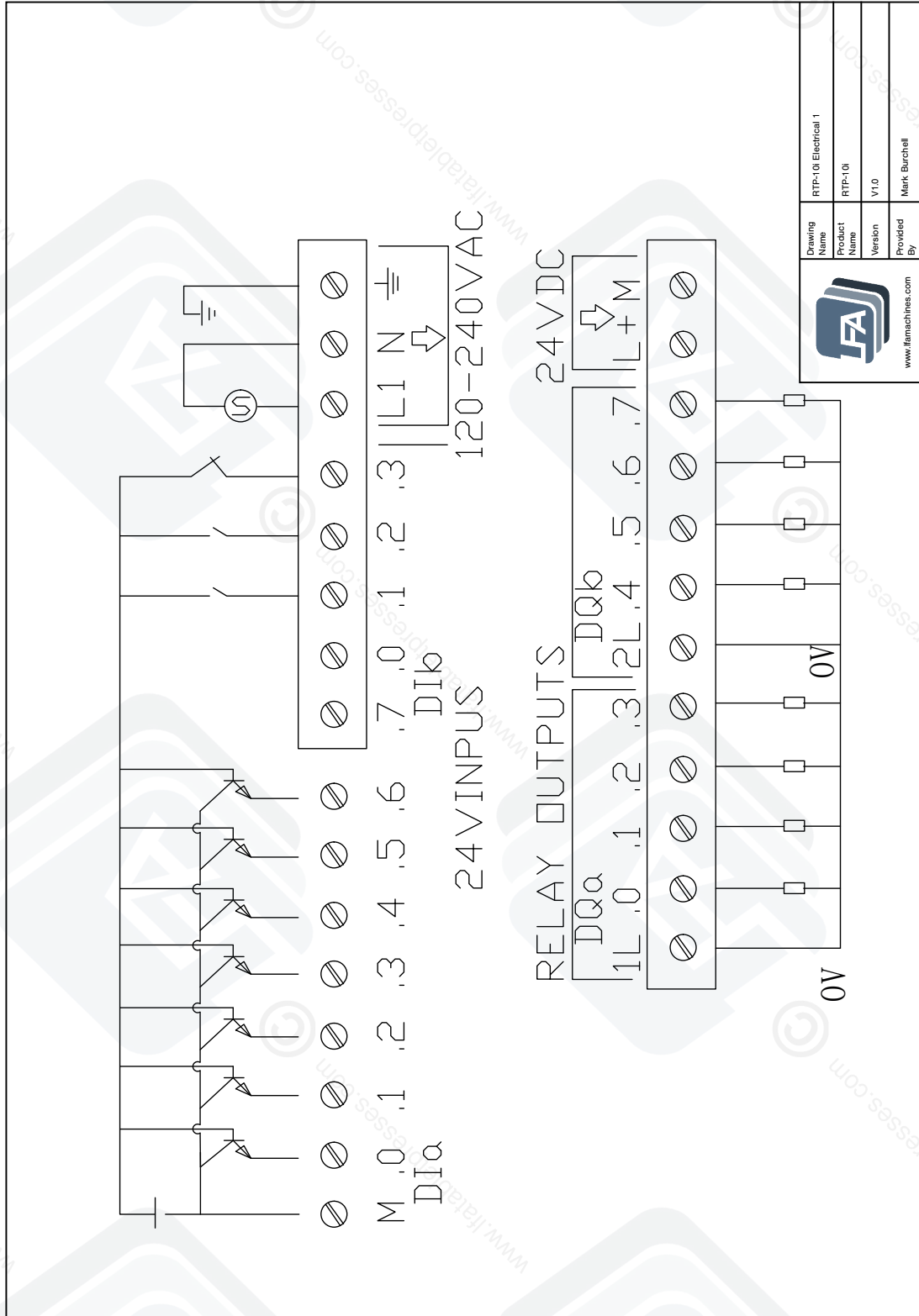

Resources

Helpful Links

Warranty

For information regarding the warranty policy of the RTP 41[®] and other LFA products, please visit <https://www.lfatabletpresses.com/warranty>

LFA Website

In order to aid you in your tablet production, LFA Machines maintains a website that offers a breadth of useful information about the RTP 41[®] and other tablet presses. Use our online tools such as the Tablet Mix Calculator to help you in your formulation production or read our regularly published articles that cover a whole range of topics about tablet presses and tablet production.

Visit the LFA homepage at <https://www.lfatabletpresses.com>

To create a free member's account, follow this link: <https://www.lfatabletpresses.com/customer/account/create>

LFA Machines YouTube Channel

Our YouTube videos provide you an opportunity to see demonstrations of how to use our tablet presses, common troubleshooting tips, and other LFA products such as capsule fillers and mixers. We regularly upload videos to give you a visual aid that will hopefully support you in your tablet production efforts. To watch our videos, visit <https://www.youtube.com/channel/UCwtbcwja77ai7vX2o34FUkQ>

LFA Machines Social Media

Social media is a great way to keep yourself updated on new developments and exciting things happening at LFA Machines. The list below contains our current social media pages:

Twitter: @lfatabletpress

Facebook: <https://www.facebook.com/lfatabletpresses>

LinkedIn: <https://www.linkedin.com/company/lfa-machines-oxford-ltd/>

Contact Us

UK

LFA Machines Oxford Ltd
Unit 4B Rowood Estate
Murdock Road
Bicester, Oxfordshire OX26 4PP
+44 01869 250234
support.uk@lfamachines.com
Monday-Friday
9AM-5PM GMT

USA

LFA Machines DFW, LLC
6601 Will Rogers Blvd
Fort Worth, TX 76140
+1 (682) 312 0034
support.usa@lfamachines.com
Monday-Friday
8AM-6PM UTC (Central)

Germany

LFA Machines Düsseldorf GmbH
Business Parc Am Trippelsberg 92
Düsseldorf, North-Rhine
Westphalia 40589
+41 21188250223
verkauf@lfamachines.com

Taiwan

LFA Machines Taiwan Ltd
7F-5, No. 2, Sec. 2 Taiwan Blvd
West District, Taichung City 403
Taiwan
+886 422031790
support.asia@lfamachines.com
Monday-Friday
9AM-5PM GMT+8



LFA MACHINES

Copyright © 2026 by LFA Machines

www.lfamachines.com

United Kingdom

Unit 4B
Murdock Road
Bicester
Oxfordshire
United Kingdom
OX26 4PP

United States

6601 Will Rogers Blvd
Fort Worth
Texas
United States
76140

Germany

Business Parc Am
Trippelsberg 92
Düsseldorf
Germany
40589

Taiwan

7F.-5, No. 2, Sec. 2
Taiwan Blvd., West Dist.,
Taichung City 403,
Taiwan