

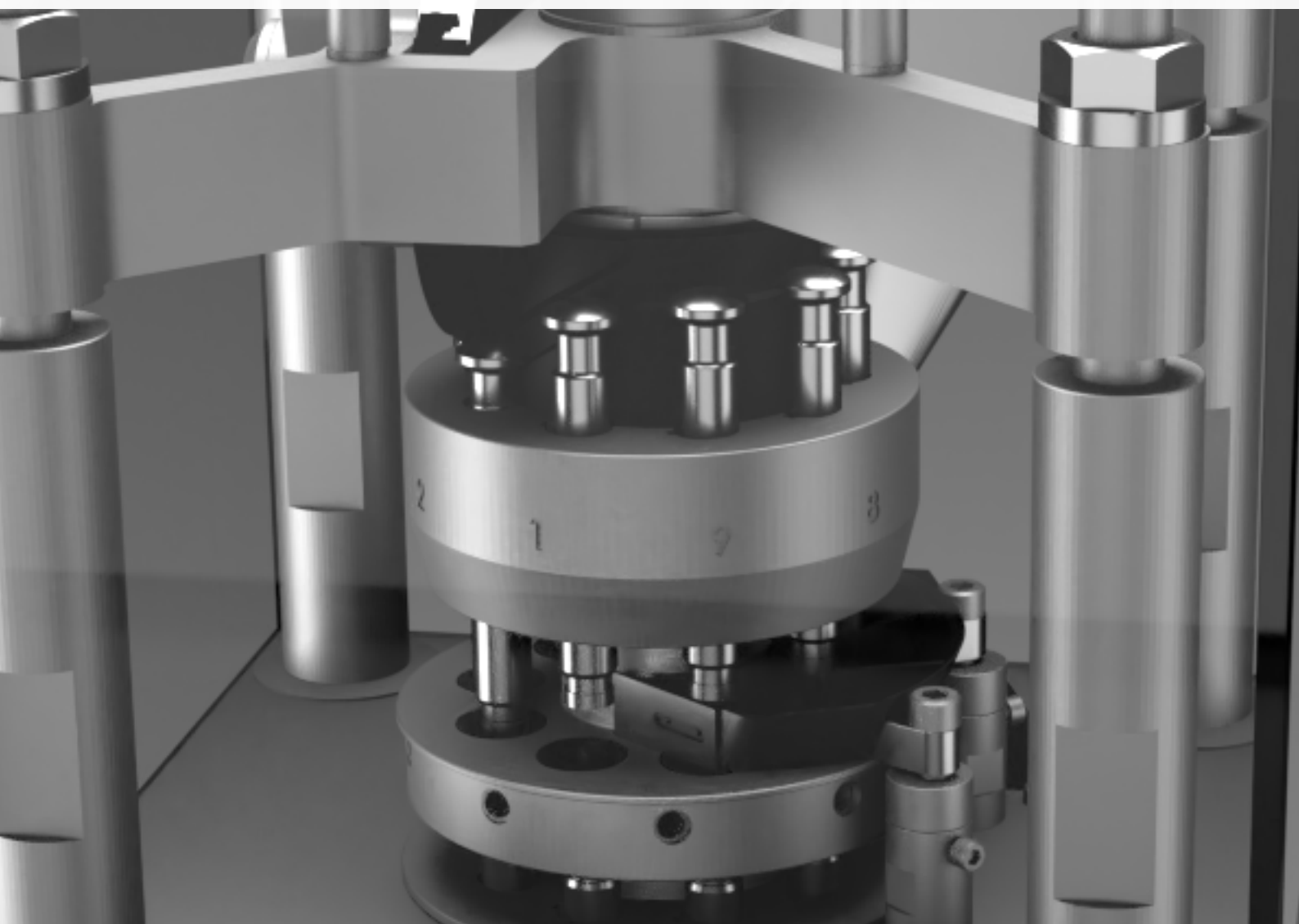

RTP 118[®] Tablet Press User Manual



We don't just sell machines—
we provide service.

Copyright Notice

© LFA Machines Oxford Limited, published in 2026 by LFA Machines Oxford Limited 2026. Registered in England and Wales, company number 08428898, registered office for service Demar House 14 Church Road East Wittering, Chichester, West Sussex, PO20 8PS.

All rights reserved. No part of this publication may be reproduced or transmitted, in any form or by any means, or stored in any retrieval system of any nature, without prior permission, except for fair dealing under the Copyright, Designs and Patents Act 1988, or in accordance with the terms of license issued by the Copyright Licensing Agency in respect of photocopying and/or reprographic reproduction. Application for permission for other use of the copyright material including permission to reproduce extracts in other published works shall be made to the publisher. Full acknowledgment of author, publisher and source must be given.

All trade marks are acknowledged and are owned by their respective owners.

Important Safety Information

READ THIS BEFORE OPERATING MACHINE

Intended Use

The intended use of this machine is to press dry raw materials into tablet form.

Potential misuse of this machine includes:

- Applying too much force to the powder.
- Trying to fill the Die with powder by hand.
- Inserting Tooling that is too big for the machine.
- Not properly mounting the machine.
- Using powders that could explode under pressure.
- Using wet or damp material.

Personal Protection

For personal protection while transporting the RTP 118®, abide by these actions:

- Use an engine hoist to lift the machine.
- Wear steel toe boots to prevent foot injury.
- Wear heavy duty grip gloves to ensure firm grasp on machine.
- Wear back support belt to prevent injury if needed.

For personal protection while operating the RTP 118®, abide by these actions:

- Avoid wearing loose jewelry to prevent machine entanglement.
- Contain long hair to prevent machine entanglement.
- Wear safety goggles.
- Wear disposable latex/rubber gloves.
- Wear a hairnet (food grade products only).
- Wear a beard net if needed (food grade products only).

General Hazards

In the case of an emergency during operation, immediately push the Emergency Stop button or turn the Isolator Switch.

- Be aware of risk of entanglement and pinch point due to moving parts.
- Do not operate in a wet environment or with wet hands due to risk of electrical shock or burn.
- Do not operate if any wires are damaged, pinched, or frayed due to risk of electrical shock or burn.
- Keep out of reach of children.
- Keep fingers away from all moving parts.
- Ensure that machine is secure with anti-vibration feet on the workspace floor.
- Inspect machine before use.
- Check that nuts and bolts are suitably tightened.
- Use this machine only for its intended use as described in this manual.
- Do not modify the machine in any way.
- Turn off and unplug the machine before conducting cleaning and maintenance.

Important Safety Information

READ THIS BEFORE OPERATING MACHINE

Symbols



WARNING

This signals potential risk for personal injury.



WARNING

This signals potential risk for electrical shock.



CAUTION

This signals potential risk for damage to the machine or other parts.

Modes for Stopping

In the case of an emergency during automatic operation, immediately unplug the RTP 118® and/ or push the Emergency Stop button or turn the Emergency Shut-Off switch:



Prop. 65 Statement for CA Residents

Based on LFA's current level of knowledge of our machines, the RTP 118® does not require a Proposition 65 warning label.

Warning for Explosive Material

This machine is not explosion proof. LFA recommends that you test your materials' explosivity before running them through this machine. If your materials are indeed explosive, do not use them with this machine.

Important Safety Information

READ THIS BEFORE OPERATING MACHINE

Installation and Safety Assessment

Due to the nature and design of this machine and its intended use in an industrial environment, it is important that before use it is installed in a cage with a mode of stopping on the outside of the cage. LFA Machines has decided that we can not possibly foresee all of the environments or situations in which this machine could be used or installed and therefore have determined that the end user must install the machine in a way that is appropriate and safe for its use.

Once the machine has been installed, it is critical that you conduct a safety assessment to ensure that it complies with all local and industry accepted safety regulations.

If you require guidance on the installation of the machine or conducting a safety assessment, please contact LFA Machines.

This machine is sold as an Unfinished Machine under the Machinery Directive (2006/42/EC) Article 13.

Table of Contents

Copyright Notice	2
Important Safety Information	3
Intended Use	3
Personal Protection	3
General Hazards	3
Symbols	4
Modes for Stopping	4
Prop. 65 Statement for CA Residents	4
Warning for Explosive Material	4
Installation and Safety Assessment	5
RTP 118® Components	7
RTP 118® Electrical Components	8
Preface	9
Training	10
On-Site/Off-Site Training	10
Training via Video Chat/Phone	10
LFA Articles	10
LFA Videos	10
Installation	11
Tools and Materials Needed	11
The Appropriate Workstation for the Machine	11
Assembly	15
Positioning the RTP 118®	16
Controls	18
Settings and Adjustment	22
Maintenance	28
General Maintenance Prescriptions	28
Lubrication	28
Dismantling for Repair and Replacement	34
Wear Parts and Causes of Damage	35
Fill Tray	45
Upper Tracking	48
Upper Pressure Cam	54
Troubleshooting	57
Common Machine/Part Issues	57
Common Tablet Issues	59
De-Jamming the RTP 118®	60
Cleaning	61
Storing the RTP 118®	64
Appendix	66
Glossary	66
Description of RTP 118® Parts	67
Material of Contact Parts	71
Technical Specifications	71
Maintenance Checklist	72
Diagrams	73
Resources	77

RTP 118[®] Components

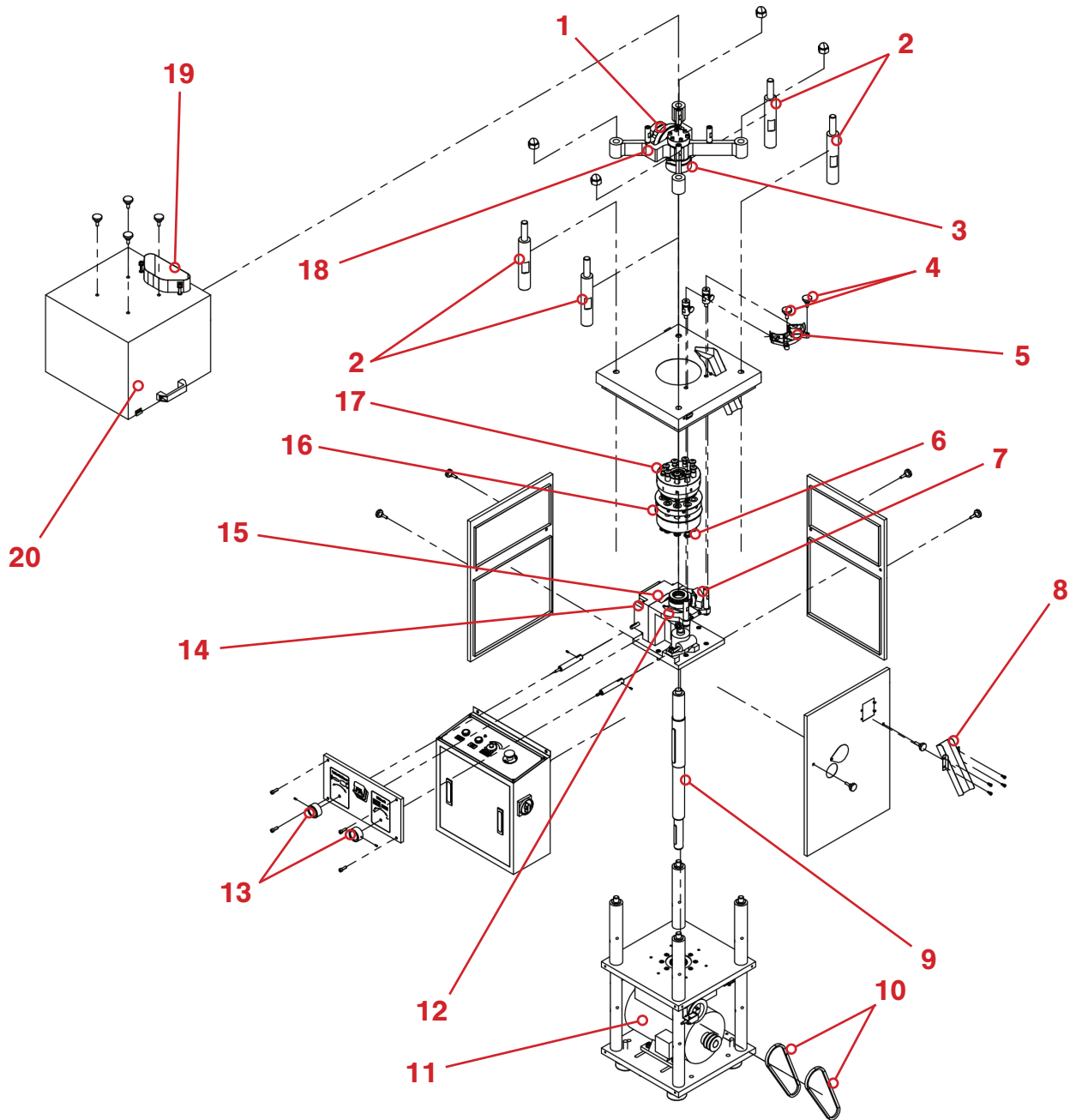

- 1. Upper Pressure Cam
- 2. Perspex Support Columns
- 3. Upper Tracking
- 4. Fill Tray Thumb Bolts
- 5. Fill Tray
- 6. Lower Punches
- 7. Ejection Cam
- 8. Ejection Chute
- 9. Main Cam Shaft
- 10. V Belts
- 11. Motor

- 12. Fill Cam
- 13. Fill Depth and Pressure Adjustment Knobs
- 14. Lower Pressure Cam Housing
- 15. Lower Pressure Cam
- 16. Turret
- 17. Upper Punches
- 18. Upper Pressure Cam Housing
- 19. Hopper
- 20. Perspex Casing

RTP 118[®] Electrical Components



WARNING

Only qualified electricians should work with these controls.



1. The variable frequency drive (for motor speed)
2. Magnetic contactor and starter
3. Breaker
4. Fuses
5. Terminal block
6. Power relay

Preface

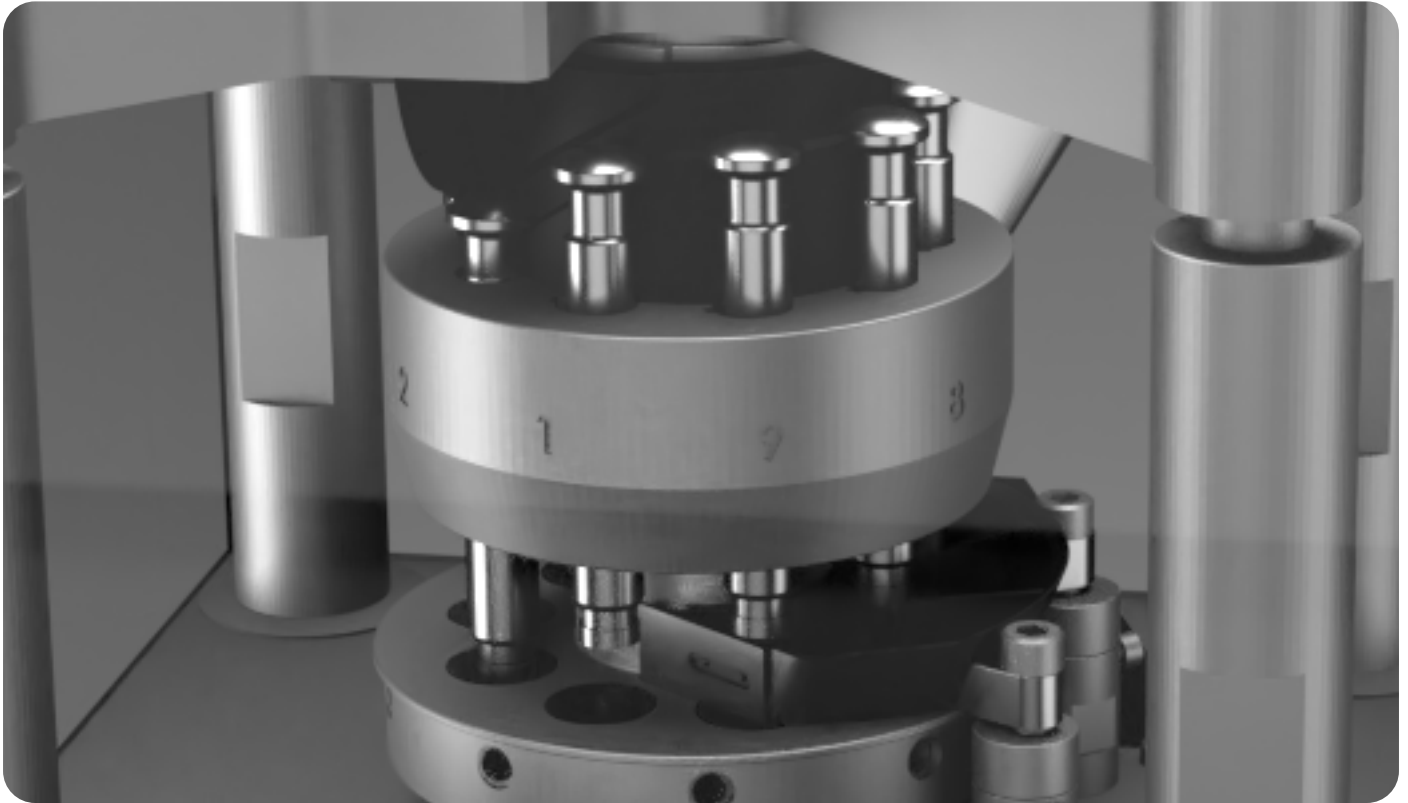

The RTP 118[®] is a rotary tablet press that can efficiently produce a high volume of quality tablets. With its nine Tooling heads and powerful motor, the RTP 118[®] has the ability to make up to 32,400 tablets an hour with a maximum of 60 kN of pressure. Rather than manually adjusting nuts and cogs, the RTP 118[®]'s advanced features include a convenient control console to manage tablet thickness, fill depth, and production speed. Particularly popular in the pharmaceutical, chemical, food, and electronic industries, the RTP 118[®] has been designed for research and development and medium-sized production with an emphasis on safety and ease of use.

The purpose of this document is to support your understanding of the RTP 118[®]'s components, features, functions, and design. With this manual, you will be able to successfully operate and maintain your RTP 118[®] machine.

The user manual's content includes:

- Important safety information
- RTP 118[®] installation instructions
- Description of the RTP 118[®]'s operation
- RTP 118[®] maintenance information
- Appendix with supplemental information

Training

RTP 118[®] training is essential for the machine's successful operation and your personal safety. There are several methods to prepare you for working with the RTP 118[®].

On-Site/Off-Site Training

LFA technicians can travel and train you at your own facility with your own machines. LFA also offers training at our UK, USA, and Taiwan facilities for all our customers and their teams.

For more information, go to <https://www.lfatabletpresses.com/services>

Training via Video Chat/Phone

Using an online video chat system, an LFA technician can interact face-to-face with you and assist with your understanding of the machine. Or, if you prefer, LFA can provide training via phone for all customers who call the office. To set up a training, call or email your local LFA office:

UK

Phone

+44 (0) 0345 165 20 25

Email

support.uk@lfamachines.com

USA

Phone

+1 (682) 312-0034

Email

support.usa@lfamachines.com

Taiwan

Phone

+886 422031790

Email

support.asia@lfamachines.com

LFA Articles

LFA writes informative articles about tablet presses, which includes instructions, procedures, and guides.

To access the articles, go to <https://www.lfatabletpresses.com/articles>

LFA Videos

LFA has created several videos involving the RTP 118[®] and other tablet presses.

To access the videos, go to <https://www.lfatabletpresses.com/videos> or <https://www.youtube.com/user/TabletPilPress>

Installation

Tools and Materials Needed

Before you install and operate the RTP 118[®], it is best to have the following tools and materials on hand for general operation and maintenance:

- Engine hoist or lift
- Lifting strap
- Hammer
- Crowbar
- Rubber mallet
- Metric wrench set
- 36 mm socket wrench
- 450 mm adjustable wrench
- Socket set
- Crosshead screwdriver
- Flathead screwdriver
- Set of metric Allen keys with ball ends
- Long wire pipe cleaner
- Cleaner (e.g. Member's Mark Commercial Lemon Disinfectant)
- Sanitizer (e.g. Member's Mark Commercial Sanitizer)
- Lubricant (NSF approved type for food grade products)
- Grease gun
- Toothbrush
- Cleaning brush set
- Plastic sheet or something similar to cover machine
- Safety goggles
- Hairnet and/or beard net (food grade products only)
- Sterile shoe covers (food grade products only)

The Appropriate Workstation for the Machine

The floor on which the machine is to be placed must support the RTP 118[®]'s 330 kg (approximately 728 lbs) weight. The static floor loading limit is 0.8 kN/m². This machine also has a single phase 220 V or 240 V (± 10%) electrical requirement, so ensure that it is near an appropriate power plug.

Environmental Conditions

It is important that the environment in which you operate and store the RTP 118[®] has the appropriate temperature and relative humidity levels. These two environmental factors can potentially cause the machine to rust and/or cause the tablets to have a lower quality. The table below shows the acceptable temperature and relative humidity levels:

Machine	Temperature		Humidity
	°C	°F	
RTP 118 [®]	18-24	64-75	45-65% RH

The shipping crate will contain the following:

1. The assembled RTP 118®



2. The Tooling (already installed)

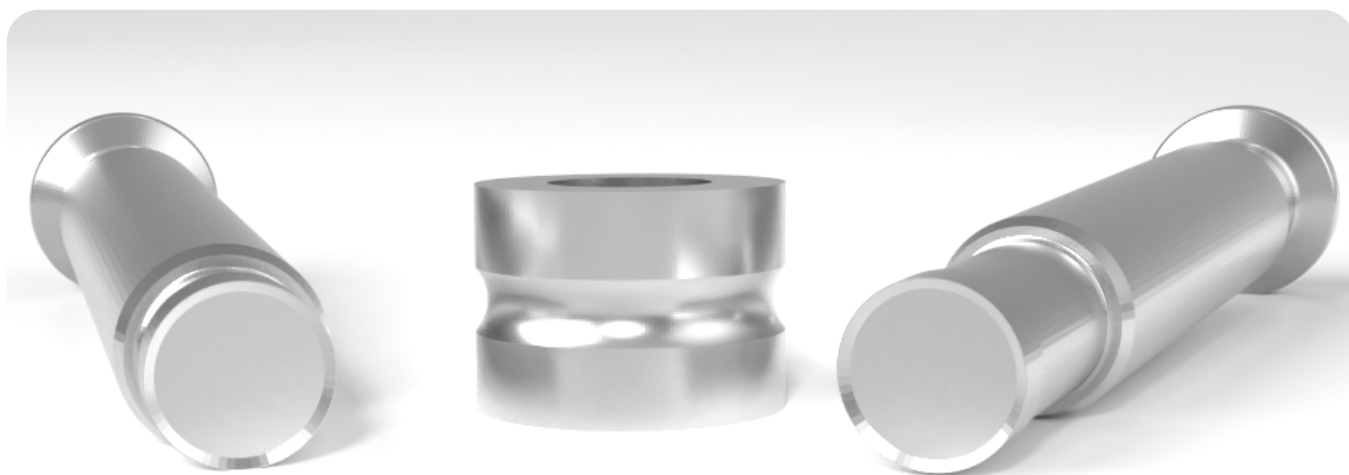

3. Toolkit including:



- Turret Brush
- Die Seat Brush
- Feeler Gauge
- 6 mm Allen key
- Die Seat Cleaner

- Die Insertion Ring
- Die Installation/Removal Bar

Unpacking the RTP 118®

Tools Needed

- Flathead screwdriver
- Hammer
- Wrench set

Instructions

1. Pry open each of the clips on the shipping container with a flathead screwdriver.



1.1 Note: Hammer the clips even further down to aid in removing the shipping container from the base.

2. Lift the top of the shipping container from its base, which is bolted to the RTP 118®.
3. Remove the plastic wrapping and set the Toolkit aside.
 - 3.1 Note: Save the wrapping for future transport and/or storage.
4. Open the left-hand and right-hand panel doors to remove the nuts and bolts from the shipping container's base with a wrench.



4.1 Note: Keep the nuts, bolts, and the shipping container's base in case you need to move or relocate the RTP 118®.

Assembly

The RTP 118[®] comes fully assembled. The RTP 118[®] also comes with anti-vibration pads underneath its base's four corners. The anti-vibration pads not only absorb noise and vibrations, but also reduce the machine's movement.



READ BEFORE INSTALLATION:

Depending on local health and safety laws, the RTP 118[®] may be required to be installed in a cage. A risk assessment is required to be conducted before installation and operation of the machine.

LFA Machines is able to advise on this. Please contact us for more information:

UK

Phone

+44 (0) 0345 165 20 25

Email

support.uk@lfamachines.com

USA

Phone

+1 (682) 312-0034

Email

support.usa@lfamachines.com

Taiwan

Phone

+886 422031790

Email

support.asia@lfamachines.com

Positioning the RTP 118[®]

WARNING: To prevent personal injury, wear steel toe boots and heavy duty grip gloves while transporting the RTP 118[®].



Because of its 330 kg (around 728 lbs) weight, LFA does NOT recommend carrying the machine manually but rather with an engine hoist. At least two people should be involved (one operating the engine hoist and one stabilizing the machine) in removing the machine from the shipping container and placing it in the workspace.

Moving the RTP 118[®] with an Engine Hoist

Tools Needed

- Set of metric Allen keys with ball ends
- Engine hoist
- Lifting straps
- Heavy duty grip gloves
- Steel toe boots

Instructions

1. Remove the Hopper from the Perspex Casing.
2. Loosen the Perspex Casing's top four screws by hand and remove it.
3. Remove all the panel doors.
4. Set aside the Handle.
5. Feed the lifting straps through the Upper Pressure Cam Housing and around the Turret.

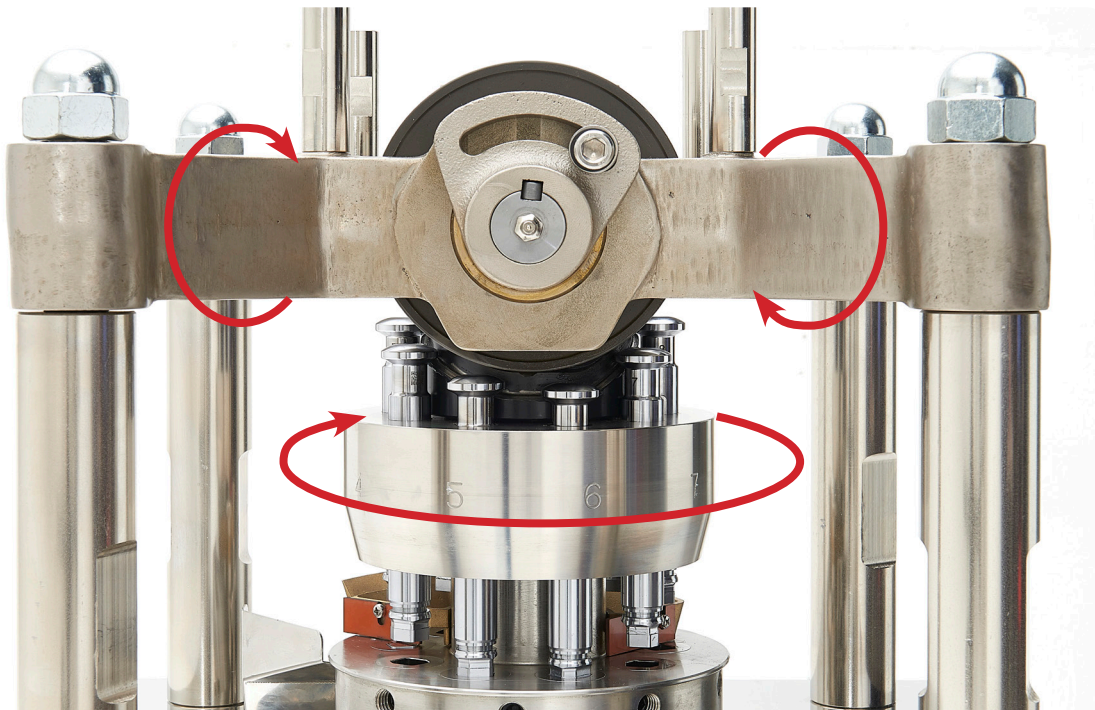

6. Carefully raise the RTP 118[®] with an engine hoist and guide it to your desired location.
 - 6.1 Note: Remember to secure the Perspex Casing, Hopper, and panel doors back onto the RTP 118[®].

In accordance with Article 13 of the European Directive 2006/42/EC, LFA Machines sells the RTP 118[®] as a partly finished machine, and it is meant to be installed into and function as a part in a production line.



After the installation of this machine, the following measures need to be taken:

- Shields must be installed in order to cover moving parts, those being in particular the Turret, Upper Punches, and Hopper.
- An emergency stop/emergency lockout/isolator switch must be installed on the outside of the machine.
- A risk assessment must be conducted on the entire production line.

If you require guidance on the installation of the machine or conducting a safety assessment, please contact LFA Machines.

Controls

Basic Components

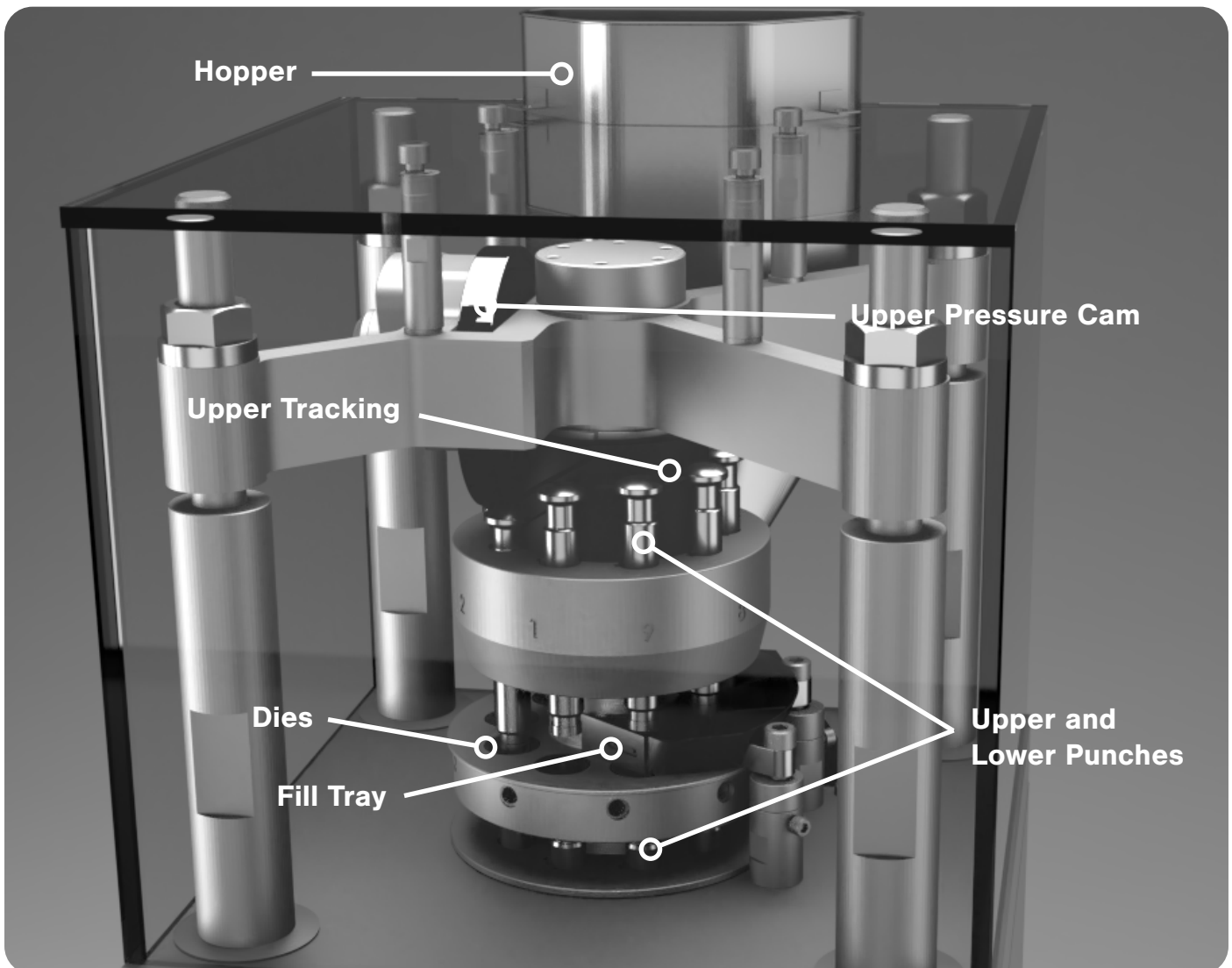

A description of the principal components follows:

- The **Hopper** holds the dry materials that will be compressed.
- The **Fill Tray** distributes the dry materials into the Die bores and pushes tablets into the Ejection Chute.
- The **Dies** define the size and shape of the powder.
- The **Upper Punches** and **Lower Punches** compress the materials within the Dies.
- The **Turret** houses the Tooling.
- The **Upper Tracking** and **Lower Tracking** guide the Tooling.
- The **Upper Pressure Cam** and **Lower Pressure Cam** compress the Upper Punches and Lower Punches to create the tablet.

Control Console

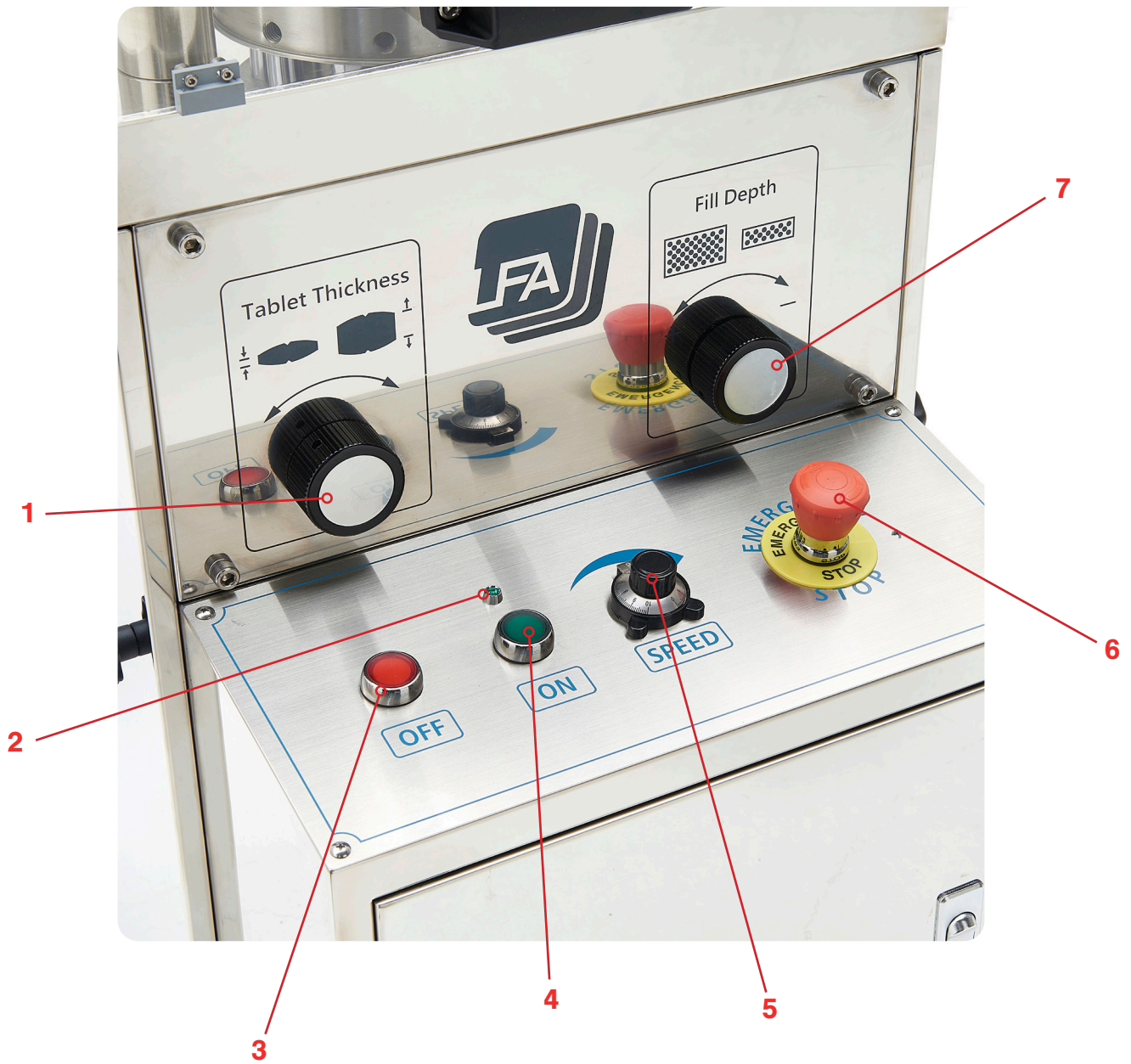

1. Adjusts punch pressure.
2. Lights up when all door panels are closed.
3. Stops machine operation.

4. Starts machine operation.
5. Controls production speed.
6. Cuts off machine in emergency.
7. Adjusts fill depth.

RTP 118® Process

The basic mechanism of the RTP 118® involves filling the Tooling (Dies, Upper Punches, and Lower Punches) with powder, compressing the powder, and ejecting the tablets.

Filling the Tooling with Powder

The dry materials are poured into the Hopper, which funnels the powder into the Fill Tray. As the machine operates, the Turret moves, which causes the Upper Punches to withdraw from the Dies. During this process, powder is moved by the Turret and is guided into the Die bores by the Fill Tray.

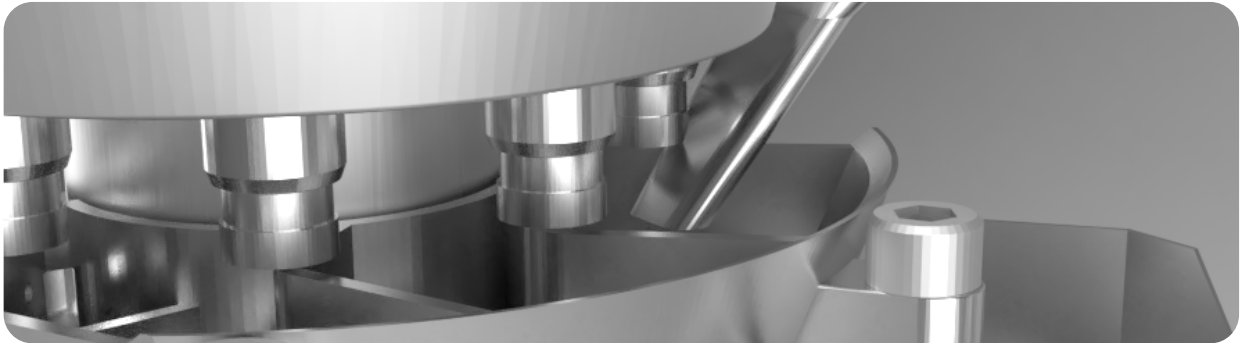

Compressing the Powder

After the Die bore is filled with powder, the Upper Punches are driven into the Dies. The Upper and Lower Punches then compress the powder under high pressure.

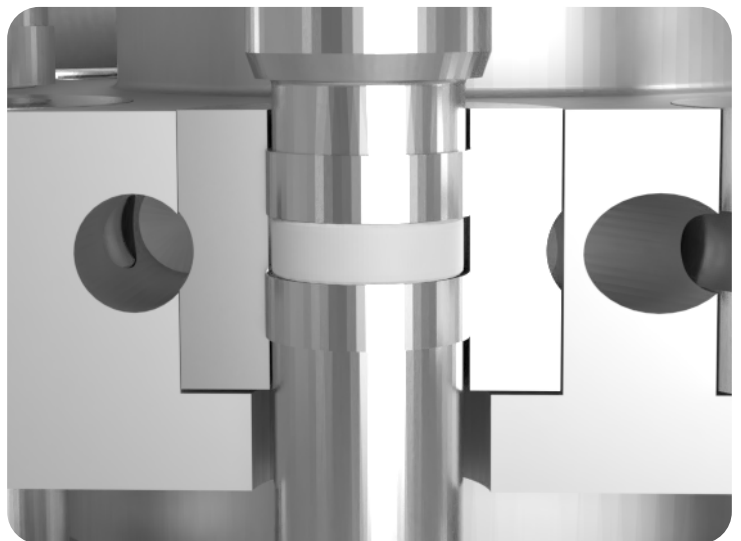
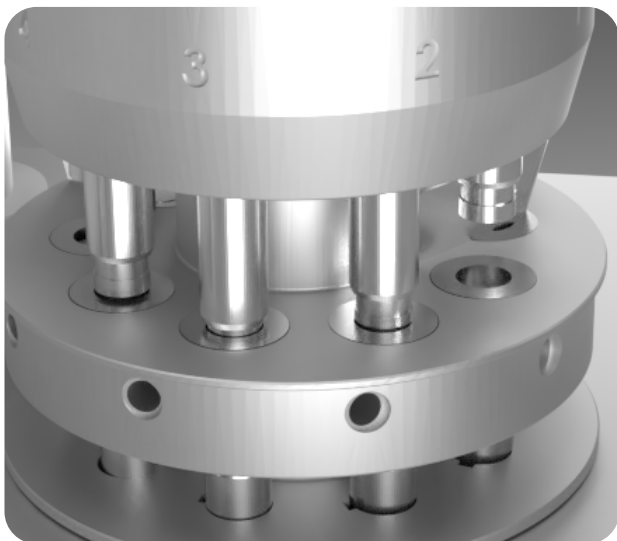

Ejecting the Tablet

After both punches compress the powder into a tablet, the Upper Tooling is withdrawn and the tablet is then pushed out of the Die bore by the Lower Punch. Once the tablet has been ejected out of the Die bore, it is slid out of the way by the Fill Tray's Scraper Blade to prepare for the next tablet compression.



How to Create Tablets with the RTP 118®

Tools and Materials Needed

- Raw material formulation
- Fully assembled RTP 118® with Hopper
- Safety goggles
- Disposable latex/rubber gloves (for food grade products and to protect hands from grease)
- Hairnet and/or beard net (food grade products only)
- Sterile shoe covers (food grade products only)



WARNING: To prevent any potential personal injury, unplug the RTP 118® from the electrical outlet.

Instructions

Note: Wear latex/rubber gloves (and appropriate food grade attire if applicable) during this process.

1. Open the right-hand side panel door.
2. Fix the Handle onto the Drive Belt Pulley's socket.

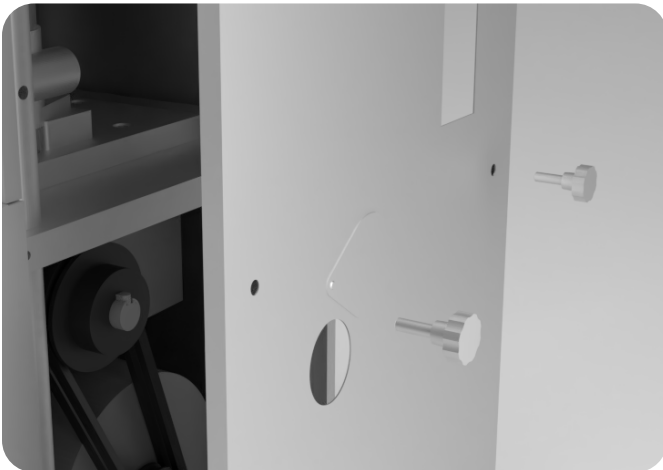

3. Turn the Handle manually for one full Turret rotation in the direction indicated by the arrow to ensure proper machine operation.
4. Pour the dry materials into the Hopper.
 - 4.1 Note: Manually press a tablet to avoid the chance of jamming the machine.
5. Remove the Handle and reinsert the panel door.
6. Plug in the RTP 118® to an electrical outlet.
7. Press the green RUN button to start the machine.
8. Press the red STOP button to stop the machine.

Settings and Adjustment

The RTP 118[®]s settings can be adjusted. Tuning the machine can help with changing the tablets' characteristics. To watch a video of tuning a machine similar to the RTP 118[®], go to <https://www.fatablepresses.com/rtp-9-tuning-your-press>

Fill Depth

At times, a tablet will be too light or too heavy, and its weight must change. This simple adjustment determines the tablet's weight.

Tools and Materials Needed

- Disposable latex/rubber gloves (for food grade products and to protect hands from grease)
- Hairnet and/or beard net (food grade products only)
- Sterile shoe covers (food grade products only)

Instructions

Note: Wear latex/rubber gloves (and appropriate food grade attire if applicable) during this process.

1. Produce test tablets to determine how the machine should be adjusted.
2. Rotate the right-hand knob on the console to change the fill depth.
 - 2.1 Note: To increase the weight rotate the knob counterclockwise (this lowers the Dosing Cam). To decrease the weight rotate the knob clockwise (this raises the Dosing Cam).
 - 2.2 Note: It may take several rotations of the knob to make the fill depth adjustment.

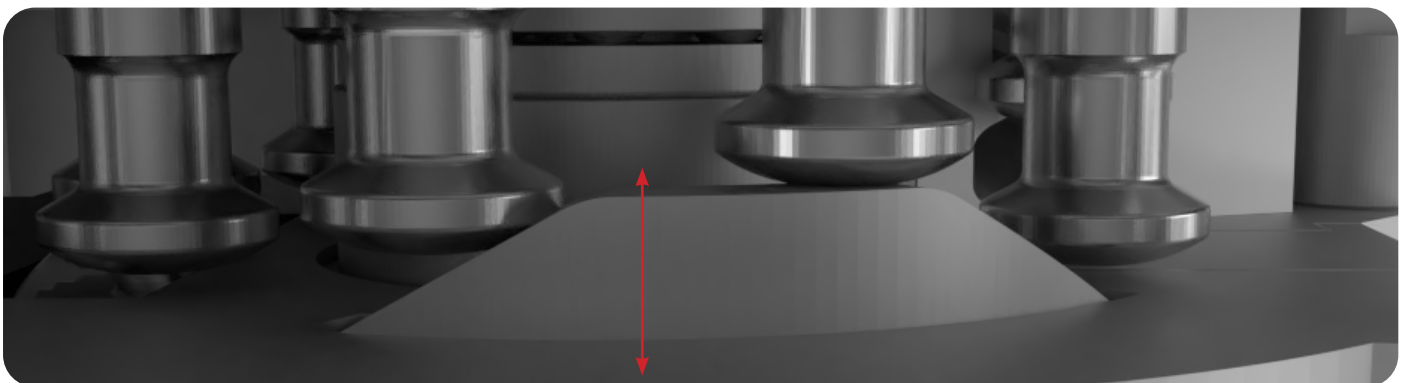

Powder Flow from Hopper

If you find that there is excess powder waste due to overflow, the Hopper will need to be adjusted.

Tools and Materials Needed

- Set of metric Allen keys
- Disposable latex/rubber gloves (for food grade products and to protect hands from grease)
- Hairnet and/or beard net (food grade products only)
- Sterile shoe covers (food grade products only)



WARNING: To prevent any potential personal injury, unplug the RTP 118® from the electrical outlet.

Instructions

Note: Wear latex/rubber gloves (and appropriate food grade attire if applicable) during this process.

1. Adjust both of the Hopper nuts and screw bolts by hand and raise/lower the Hopper to the desired position inside the Fill Tray's gate.

1.1 Note: The lower and closer the Hopper is to the Die table, the less flow there will be.

1

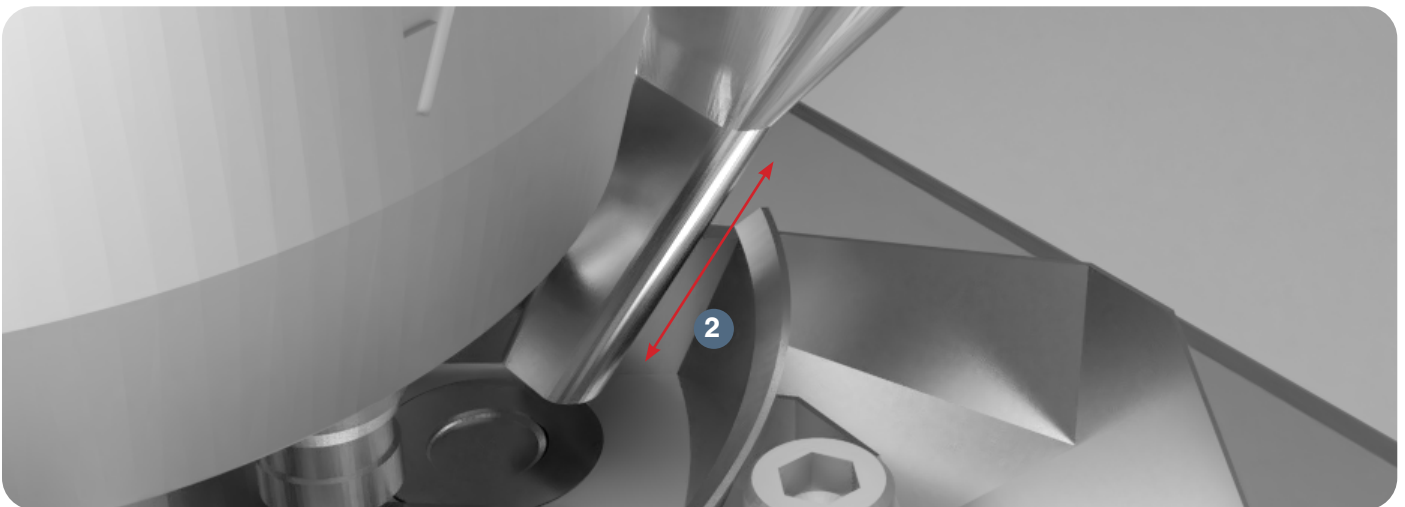
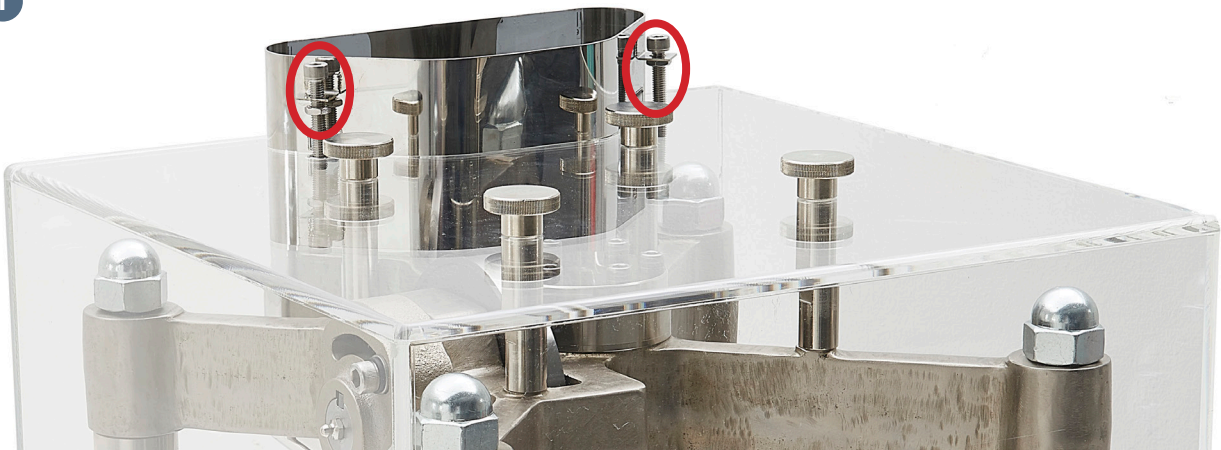

Fill Tray Height

The size of granules in your powder can affect how smoothly dry materials are moved through the Fill Tray, which can affect how much powder is wasted. Sometimes this requires the Fill Tray's height to be adjusted.

To watch a video of Fill Tray calibration on a similar machine, go to <https://www.lfatabletpresses.com/rtp-9-adjusting-feed-frame>

Tools and Materials Needed

- Set of metric Allen keys
- Feeler gauge
- Disposable latex/rubber gloves (for food grade products and to protect hands from grease)
- Hairnet and/or beard net (food grade products only)
- Sterile shoe covers (food grade products only)



WARNING: To prevent any potential personal injury, unplug the RTP 118[®] from the electrical outlet.

Instructions

Note: Wear latex/rubber gloves (and appropriate food grade attire if applicable) during this process.

1. Lift up the Hopper and loosen the Perspex Casing's top four screws and remove it.
2. Loosen the Fill Tray Thumb Bolts by hand and remove them.
3. Loosen the Fill Tray Scrapers with a crosshead screwdriver.



4. Run a feeler gauge between the Fill Tray and the Turret to determine the adjustment.
 - 4.1 Note: Start at 0.15 mm and raise appropriately if there is no powder waste/damage to the Fill Tray. If there is waste, lower it.

5. Adjust the Fill Tray Height Adjusters accordingly and tighten their bolts.



6. Resecure the Fill Tray Scrapers with a crosshead screwdriver.

7. Tighten the Fill Tray Thumb Bolts by hand.

8. Resecure the Perspex Casing and reinsert the Hopper.

Tablet Thickness

Sometimes you will need to adjust the tablets' thickness so that the pressure relative to the fill is high, which results in creating a solid tablet.

Tools and Materials Needed

- Disposable latex/rubber gloves (for food grade products and to protect hands from grease)
- Hairnet and/or beard net (food grade products only)
- Sterile shoe covers (food grade products only)
-

Instructions

Note: Wear latex/rubber gloves (and appropriate food grade attire if applicable) during this process.

1. Produce test tablets to determine how the machine should be adjusted.
2. Rotate the left-hand knob on the console to change the punch pressure.
 - 2.1 Note: To make tablets thinner, rotate the knob counterclockwise (increase punch pressure). To make tablets thicker, rotate the knob clockwise (decrease punch pressure).
 - 2.2 Note: The pressure adjustment knob can be sensitive. Make adjustments in small increments.

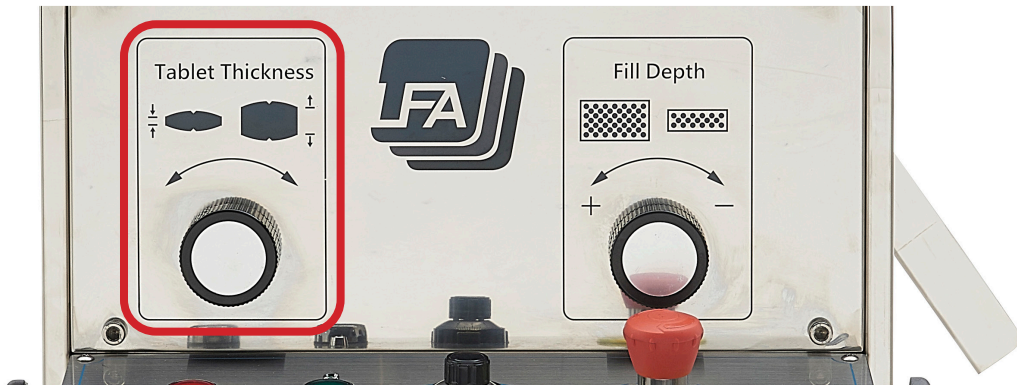

CAUTION: If the punch pressure is increased too much, the machine could sustain a lot of damage even though the machine will automatically cut off. Simply decrease the punch pressure to its limit to get the machine running again.

Upper Punch Penetration

If the tablet needs to be around 1 mm thicker or thinner, you can adjust the Upper Pressure Cam.

Watch a video of upper punch penetration adjustment on a similar machine at <https://www.ifatabletpresses.com/rtp-9-upper-roller-adjustment>

Tools and Materials Needed

- Set of metric Allen keys
- Disposable latex/rubber gloves (for food grade products and to protect hands from grease)
- Hairnet and/or beard net (food grade products only)
- Sterile shoe covers (food grade products only)



WARNING: To prevent any potential personal injury, unplug the RTP 118® from the electrical outlet.

Instructions

Note: Wear latex/rubber gloves (and appropriate food grade attire if applicable) during this process.

1. Lift up the Hopper and loosen the Perspex Casing's top four screws and remove it.
2. Loosen the Upper Pressure Cam Pressure Adjuster's bolt with an Allen key.
3. Move the Upper Pressure Cam Housing Adjuster to increase or decrease the Upper Punch's penetration.

3.1 Note: To increase, move clockwise. To decrease, move counterclockwise.



4. Resecure the Upper Pressure Cam Pressure Adjuster's bolt with an Allen key.
5. Resecure the Perspex Casing and reinsert the Hopper.

Maintenance

To ensure that the RTP 118[®] will have a long operational life, maintenance is essential. This section includes methods for replacing parts, troubleshooting solutions, and how often to grease and clean your machines to keep its performance optimal.

General Maintenance Prescriptions

- Use the maintenance checklist (found in the Appendix) before, during, and after machine operation.
- Make sure all grease points are maintained and regularly lubricated.
- Use an appropriate amount of lubricant. Excess grease can drip into the tablets as they are formed.
- Before reassembling the machine after cleaning, make sure that the parts are dried and oiled.
- Constantly check for any loose nuts and/or screws before, during, and after machine operation.
- After each run, place the Tooling in an airtight container and cover in lubricant.

Lubrication

Regularly greasing your machine is vital to prolonging its operational life. Parts that are not greased properly can make the machine seize up and cause major problems later. LFA recommends maintaining a lubrication schedule for your RTP 118[®], which can be found in this section.

Tools and Materials Needed

- Grease gun
- RTP 118[®] Toolkit (comes with machine)
- NLGI Grade 1 and Grade 2 grease
- SAE 10 oil
- Set of metric Allen keys with ball ends
- Disposable latex/rubber gloves (for food grade products and to protect hands from grease)
- Hairnet and/or beard net (food grade products only)
- Sterile shoe covers (food grade products only)



WARNING: To prevent any potential personal injury, unplug the RTP 118[®] from the electrical outlet.

Instructions

Note: Wear latex/rubber gloves (and appropriate food grade attire if applicable) during this process.

1. Lift up the Hopper and loosen the Perspex Casing's top four screws and remove it.



2. Remove the Upper Punches and Lower Punches.

2.1 For additional assistance, please refer to the Tooling removal instructions on page 36.

3. Lubricate the heads of the Upper Punches and Lower Punches with NLGI Grade 1 grease.

4. Lubricate the barrels of the Upper Punches and Lower Punches with SAE 10 oil.



5. Lubricate the Upper Tracking with NLGI Grade 1 grease.

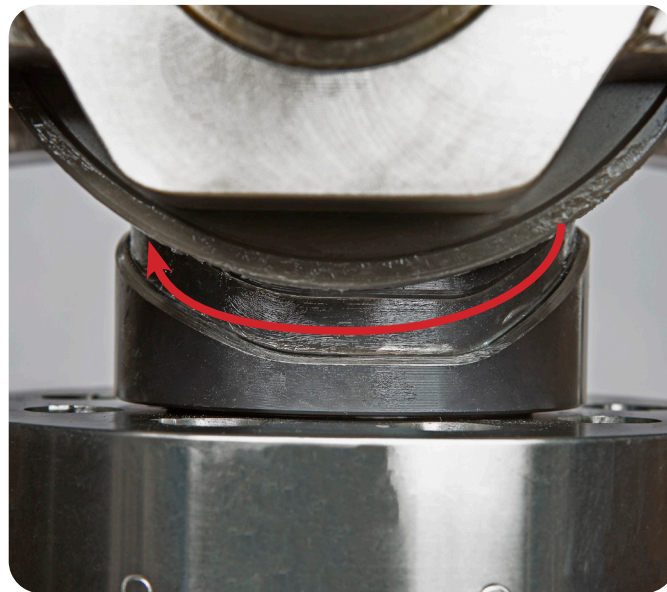

6. Open the left-hand side panel door.
7. Lubricate the Lower Pressure Cam Shaft's grease nipple with NLGI Grade 2 grease.
8. Lubricate the Pressure Adjustment Gear with NLGI Grade 2 grease.

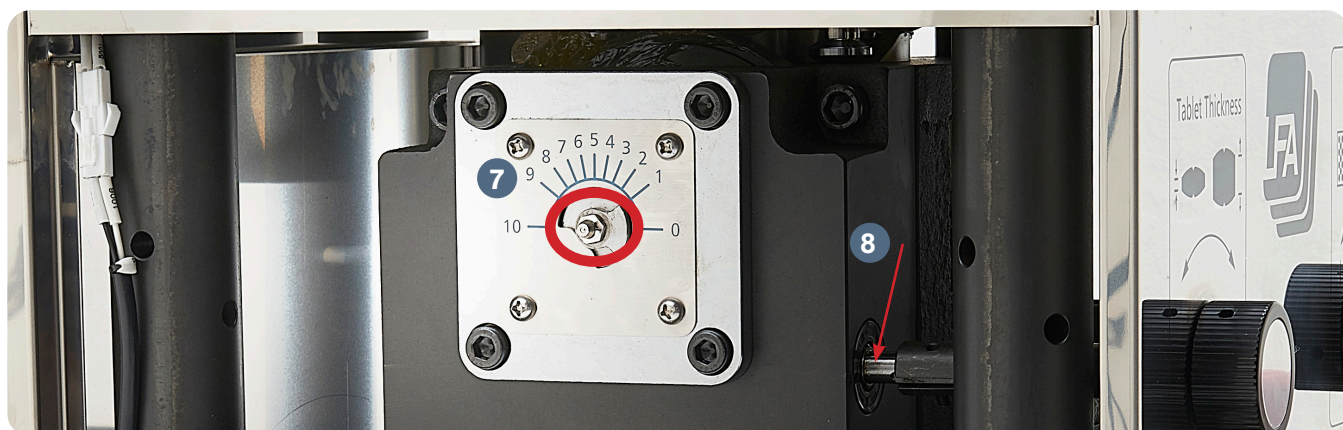

9. Lubricate the Upper Pressure Cam Shaft's grease nipple with NLGI Grade 2 grease.

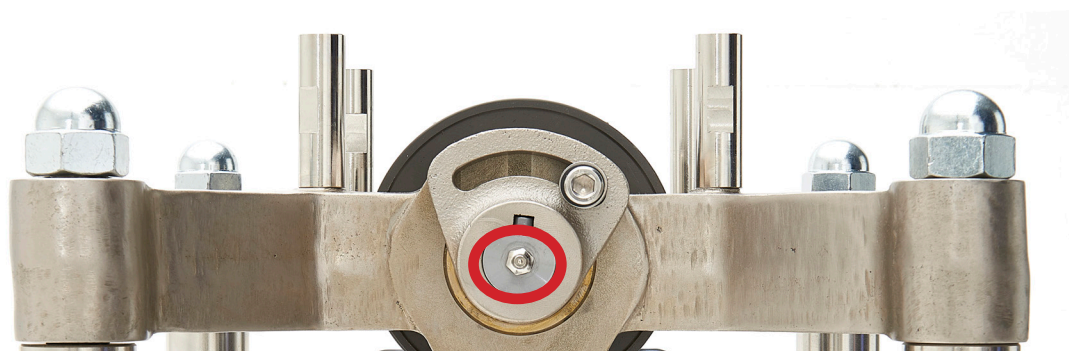





10. Open the right-hand side panel door.



11. Lubricate the Fill Adjustment Gear's grease nipple with NLGI Grade 2 grease.

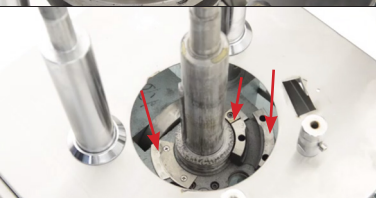
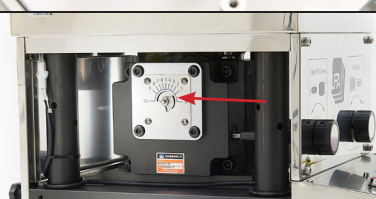

Lubrication Schedule

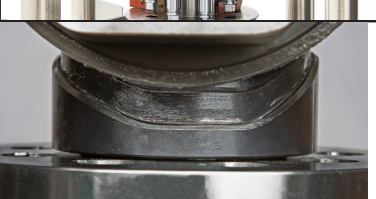
LFA recommends the following RTP 118® parts to be lubricated according to the following frequency:

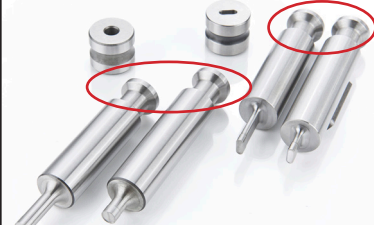
Part	Location	Image	Frequency	Type of Lubricant
Drive Shaft Bearings	Ball bearings at the bottom of the Main Drive Shaft		Inspect after every 3 months or 100,000 tablets and apply if dry. If old, gritty grease is present, clean before lubricating.	NLGI Grade 2
Turret Bearings	Ball bearings inside the center of the Turret		Inspect after every 3 months or 100,000 tablets and apply if dry. If old, gritty grease is present, clean before lubricating.	NLGI Grade 2
Lower Tracking	Inside the Main Drive Shaft's bore and the Ejection Cam, Fill Cam, and Dosing Cam		Inspect after every 3 months or 100,000 tablets and apply if dry. If old, gritty grease is present, clean before lubricating.	NLGI Grade 2
Grease Nipple on Lower Pressure Cam Shaft	On left side of RTP 118® (open panel door)		Apply after every 100,000 tablets.	NLGI Grade 2
Grease Nipple on Upper Pressure Cam Shaft	On the back of the Upper Pressure Cam Housing		Apply after every 100,000 tablets.	NLGI Grade 2
Upper Tracking	Tracking on Turret that guides the Upper Punches		Apply when dry before beginning batch.	NLGI Grade 1
Pressure Adjustment Gear	Gear on side of Lower Cam Roller's housing (open left-hand side panel door)		Inspect after every 3 months or 100,000 tablets and apply if dry. If old, gritty grease is present, clean before lubricating.	NLGI Grade 2

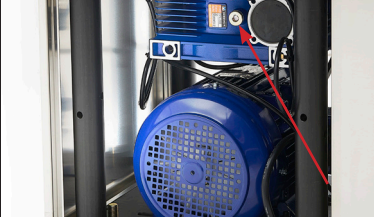
Part	Location	Image	Frequency	Type of Lubricant
Fill Adjustment Gear	Grease nipple located next to the Fill Adjustment Gear (open right-hand side panel door)		Inspect after every 3 months or 100,000 tablets and apply if dry.	NLGI Grade 2
Tooling Heads	Heads of Upper Punches and Lower Punches		Inspect and apply when dry.	NLGI Grade 1
Tooling	Airtight container		Cover and store in oil after cleaning.	Mineral oil
Tooling Barrels	The main shaft of the Upper Punches and Lower Punches		Lubricate every time Tooling is installed in the press.	SAE 10
Gearbox	On the Gearbox		Inspect after every 3 months.	460 Grade Worm Gear Oil

Dismantling for Repair and Replacement

Eventually due to wear and tear, some parts of the RTP 118® will need to be removed for repair and replacement. To prevent any delays in your tablet production, it is best practice to keep extra parts just in case.

Warranty

To access LFA's warranty policy, go to <https://www.lfatabletpresses.com/warranty>

If your part is eligible for warranty, have your part's serial number on hand and please contact LFA:

UK

Phone

+44 (0) 0345 165 20 25

Email

support.uk@lfamachines.com

USA

Phone

+1 (682) 312-0309

Email

support.usa@lfamachines.com

Taiwan

Phone

+886 422031790

Email

support.asia@lfamachines.com



WARNING: To prevent any potential personal injury, ALWAYS unplug the RTP 118® from the electrical outlet when replacing parts.

Wear Parts and Causes of Damage

Wear Part	Cause of Damage
Tooling	The Tooling can become chipped or broken. Lead times for a new set of Tooling can take as long as 6-8 weeks, so LFA recommends having a spare set or two.
Fill Tray	On the RTP 118®, the Fill Tray spreads the powder over the Die Table and into the Die bores. It is formed from cast brass and is designed to wear. It protects the Turret/Die Table and the Tooling. If this part is damaged by a Die sitting above the Die Table, it is possible to refinish it using a flat stone, some oil, and 3000 grit sandpaper. Eventually when the "gates" underneath are so small that powder is unable to pass through smoothly, or if there is a catastrophic failure, this part will need to be replaced.
Fill Tray Scrapers	One Fill Tray Scraper is used to take off the excess powder from the Die Table after the Dosing Cam has forced out the powder. The other Fill Tray Scraper is used to aid in tablet ejection. These parts can become damaged if a Die is protruding from the Die Table or if a Lower Punch jumps up from the Dosing Cam. To reduce waste, these parts will need to be replaced if damaged.
Ejection Cam	The Ejection Cam ejects the tablets at the correct moment in the Turret's cycle. This part is not able to be tuned and is fixed in place. Over time this part can wear, and the tablet's ejection point can get lower until they are not ejecting correctly from the Die bores. The three main causes of this are: 1) tight Lower Punches due to buildup of excess fines in powder, 2) high ejection forces that are caused by sticky powders clinging to the Die bore's wall, and 3) powder that mixes with oil/grease, which creates a sandpaper effect on the Ejection Cam.
Fill Cam	The Fill Cam pulls down the Lower Punches to fill the Die bores with powder. This part is built from brass and is designed to wear to protect the Tooling and the press. The main causes of a worn Fill Cam are: 1) tight Lower Punches due to buildup of excess fines in powder, 2) use of incorrect Tooling with the wrong head profile, and 3) powder that mixes with oil/grease, which creates a sandpaper effect on the Fill Cam.
Dosing Cam	The Dosing Cam is used to calibrate the press to produce the desired tablet weight. This is done by pushing excess powder out of the Die bore after it has been filled. The main causes of a worn Dosing Cam are: 1) Tight Lower Punches due to buildup of excess fines in powder, 2) use of incorrect Tooling with the wrong head profile, and 3) powder that mixes with oil/grease, which creates a sandpaper effect on the Dosing Cam.
Upper/Lower Pressure Cam	The Roller Cams apply all the pressure onto the Tooling. If these become worn, it can cause damage to the tops of the Tooling and affect tablet hardness and consistency. This is predominantly caused by general wear and, in some cases, excess punch pressure being applied.

Tooling

If you want to change the shape and diameter of the tablet, or if any of the Upper Punches, Lower Punches, and/or Dies you currently have are damaged, it is necessary to change the Tooling. To buy new Tooling from LFA, simply go to <https://www.lfatabletpresses.com/products/tablet-press-tooling>

To watch a video of a similar machine's Tooling change, go to <https://www.lfatabletpresses.com/rtp-9-tooling-change>

Tools and Materials Needed

- Set of metric Allen keys with ball ends
- Tooling (Upper Punches, Dies, and Lower Punches)
- RTP 118[®] Toolkit (comes with machine)
- Lubricant (NSF approved for food grade products)
- Disposable latex/rubber gloves (for food grade products and to protect hands from grease)
- Hairnet and/or beard net (food grade products only)
- Sterile shoe covers (food grade products only)



WARNING: To prevent any potential personal injury, ALWAYS unplug the RTP 118[®] from the electrical outlet when replacing parts.

Instructions

Note: Wear latex/rubber gloves (and appropriate food grade attire if applicable) during this process.

Remove the Old Tooling

1. Lift up the Hopper and loosen the Perspex Casing's top four screws and remove it.



2. Loosen the Fill Tray's Thumb Bolts and remove them by hand.



- 3. Remove the Fill Tray from the Turret.
- 4. Remove the right-hand panel door.
- 5. Insert the Handle onto the Drive Belt Pulley socket.



6. Pull the Upper Punch upwards to remove it from the Turret.



- 7. Rotate the Handle until the next Upper Punch can be removed.
- 8. Repeat steps 6-7 until all Upper Punches are removed.
- 9. Remove the Lower Punch and Die Removal Plate with an Allen key.

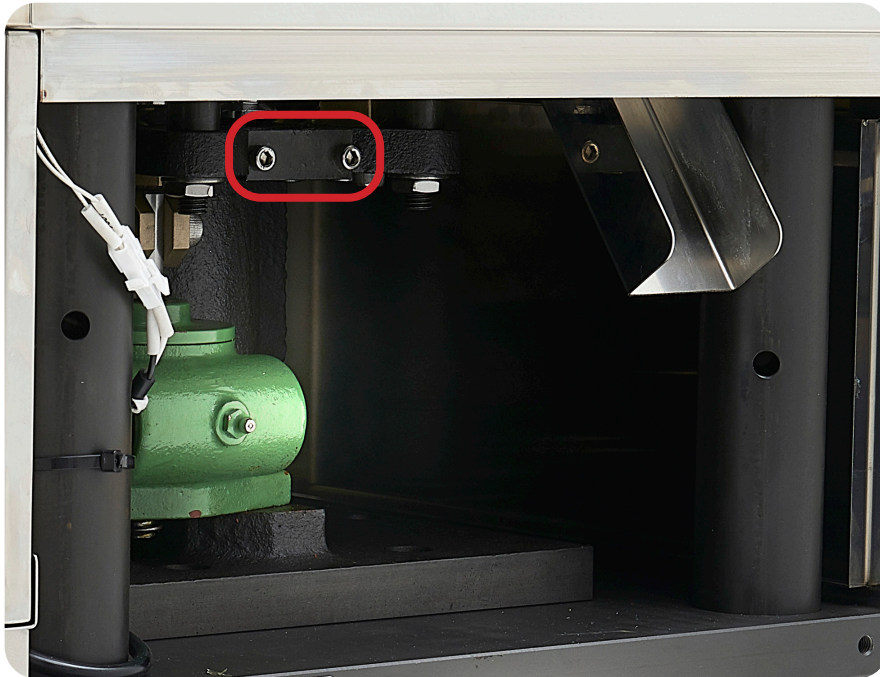

- 10. Rotate the Handle until a Lower Punch is aligned with where the Lower Punch and Die Removal Plate was previously.
- 11. Gently pull on the Lower Punch's head through the hole.
 - 11.1 Note: Be sure to have a firm hold on the Lower Punch so that it does not fall and become damaged.

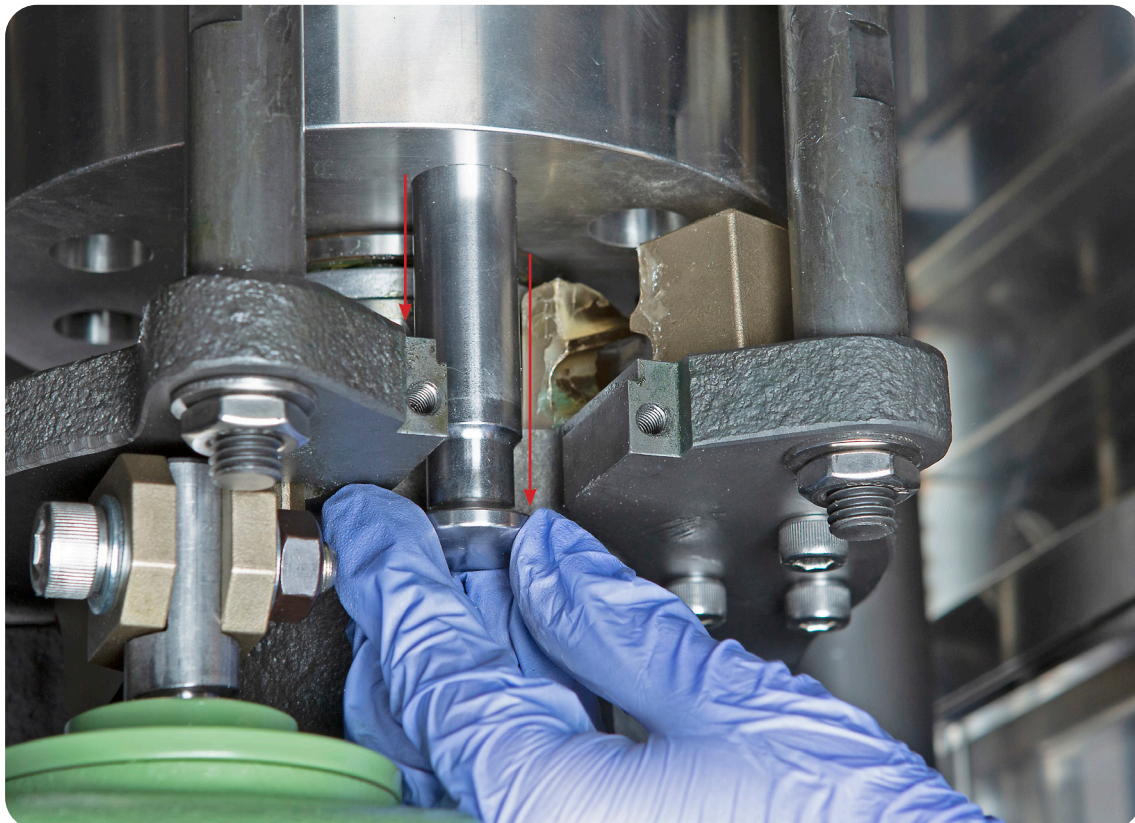

- 12. Repeat steps 10-11 until all Lower Punches are removed.

13. Rotate the Handle until a Die is aligned with where the Lower Punch and Die Removal Plate was previously.

14. Remove Die's set screw with an Allen key.

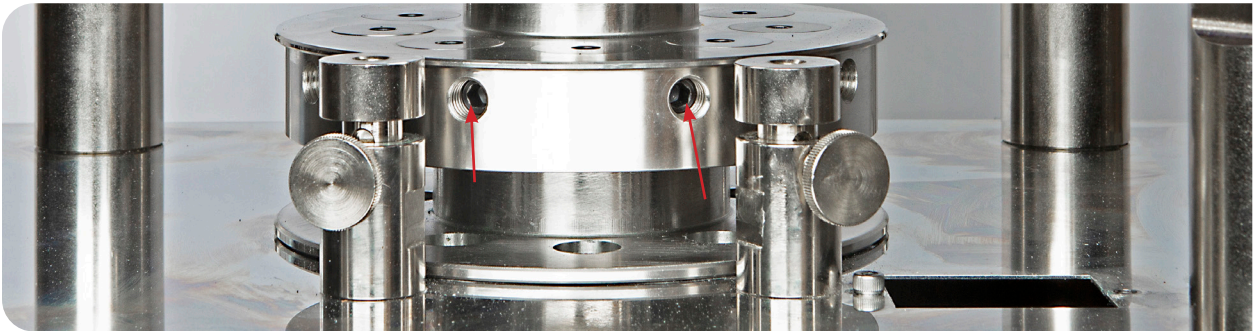

15. Hold the Die Removal Bar up through the hole from which the Lower Punches were removed and into the Turret.

16. Tap the Die from underneath the Die Plate until it pops up and remove it.



17. Repeat steps 13-16 until all Dies are removed.

Note: To help ensure that the Dies are inserted correctly, LFA recommends using an Insertion Ring. You can order the Die Seat Cleaner and Insertion Ring on our website at <https://www.fatablepresses.com/die-seat-cleaner-insertion-ring>



Replace the Tooling

18. Position the new Die on the Turret.

18.1 Note: Place a bit of grease around the new Die's sides to make insertion easier.

19. Insert the Die Installation Bar through the Upper Punch's hole and over the new Die.

20 Tap the Die Installation Bar until the new Die is inserted into the Turret.

20.1 Note: Make sure that the new Die is flush with the Turret.



21. Reinsert the Die's set screw in the Turret and tighten with an Allen key.

21.1 Note: The Die's set screw are to be tensioned at 16 lbs/ft.

22. Rotate the Handle until the next new Die can be inserted.

23. Repeat steps 18-22 until all the new Dies are secured in the Turret.

24. Insert a new Lower Punch up through the Lower Punch and Die Removal Plate's hole and into the new Die's bore.

24.1 Note: Lubricate the barrel of the Lower Punch.



25. Place the new Lower Punch's head on the Lower Tracking.

26. Rotate the Handle until the next new Lower Punch can be inserted.

27. Repeat steps 24-26 until all the new Lower Punches are inserted into the Turret.

28. Reinsert the Lower Punch and Die Removal Plate and secure it with an Allen key.

28.1 Note: Manually turn the RTP 118® Turret for a couple of rotations to ensure that the new Lower Punches are situated correctly.

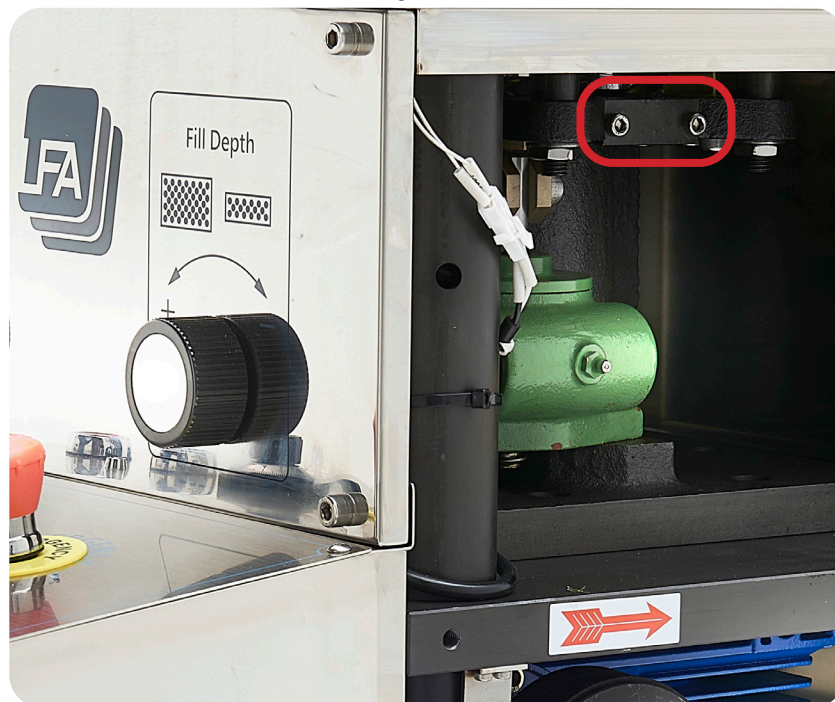

29. Insert a new Upper Punch through the top of the Turret.

29.1 Note: Lubricate the barrel of the Upper Punch.

30. Place the new Upper Punch's head on the Upper Tracking.

30.1 Note: Be sure that the new Upper Punch's head is above the Upper Tracking to prevent damage.



31. Rotate the Handle until the next new Upper Punch can be inserted.

32. Repeat steps 29-30 until all the new Upper Punches are inserted into the Turret.

32.1 Note: Manually turn the RTP 118® Turret for a couple of rotations to ensure that the new Upper Punches are situated correctly.

33. Remove the Handle from the Drive Belt Pulley.

34. Place the Fill Tray back on the Turret.

34.1 Note: Please refer to the Fill Tray Height adjustment instructions on page 24 for calibration.

35. Tighten the Fill Tray Thumb Bolts back onto the Fill Tray and RTP 118® by hand.

36. Resecure the Perspex Casing and the Hopper.

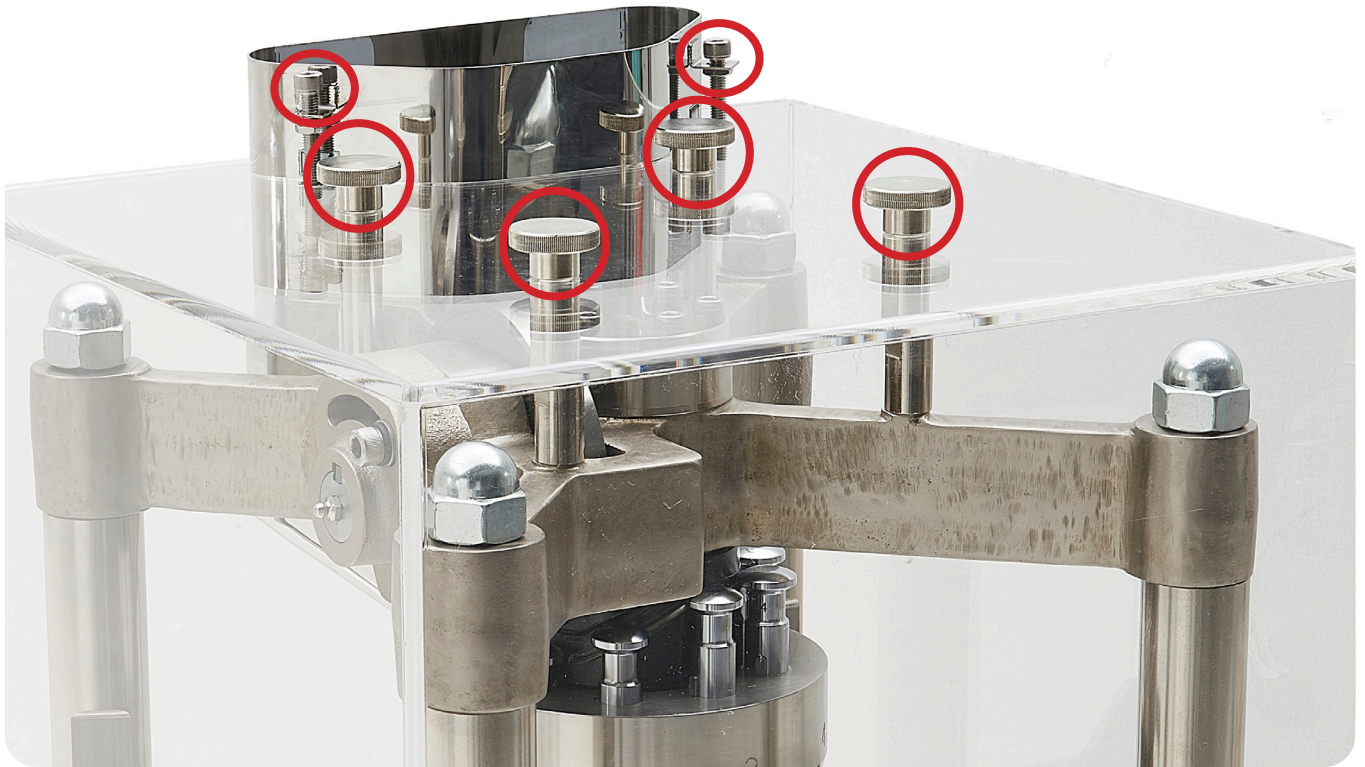

Fill Tray

The Fill Tray helps channel the dry materials into the Die bores and also pushes the tablets out of the way and into the Ejection Chute. This part is designed to wear to avoid damaging the Tooling and/or Turret, so it may need to be replaced. These instructions also apply to the Fill Tray Scrapers removal and replacement.

Tools and Materials Needed

- Set of metric Allen keys with ball ends
- Crosshead screwdriver
- New Fill Tray part
- Disposable latex/rubber gloves (for food grade products and to protect hands from grease)
- Hairnet and/or beard net (food grade products only)
- Sterile shoe covers (food grade products only)



WARNING: To prevent any potential personal injury, ALWAYS unplug the RTP 118[®] from the electrical outlet when replacing parts.

Instructions

Note: Wear latex/rubber gloves (and appropriate food grade attire if applicable) during this process.

Remove the Fill Tray

1. Lift up the Hopper and loosen the Perspex Casing's top four screws and remove it.



2. Loosen the Fill Tray's thumb bolts by hand and remove them.



3. Remove the Fill Tray Scrapers from the Fill Tray with a crosshead screwdriver.



4. Take off the Fill Tray from the Turret.

Replace the Fill Tray

5. Loosely attach the Fill Tray Scrapers on the new Fill Tray with a crosshead screwdriver.
6. Place the new Fill Tray on the Turret and align it with the Fill Tray Height Adjusters' holes.



7. Screw in the Fill Tray Thumb Bolts through the Fill Tray and Fill Tray Height Adjusters.
7.1 Note: Please refer to the Fill Tray Height adjustment instructions on page 24 for calibration.
8. Tighten the Fill Tray Scrapers with a crosshead screwdriver.
8.1 Note: It is important to make sure that the Fill Tray Scraper blade furthest from the Ejection Chute is firmly up against the Die Table of the Turret. To do this, push down on the top of the blade while tightening the screws that hold it in place. The Fill Tray Scraper blade closest to the Ejection Chute needs to not be touching the Die Table and should be mounted approximately $\frac{1}{3}$ of the height of the tablet from the surface of the Die Table.
9. Resecure the Perspex Casing and the Hopper.

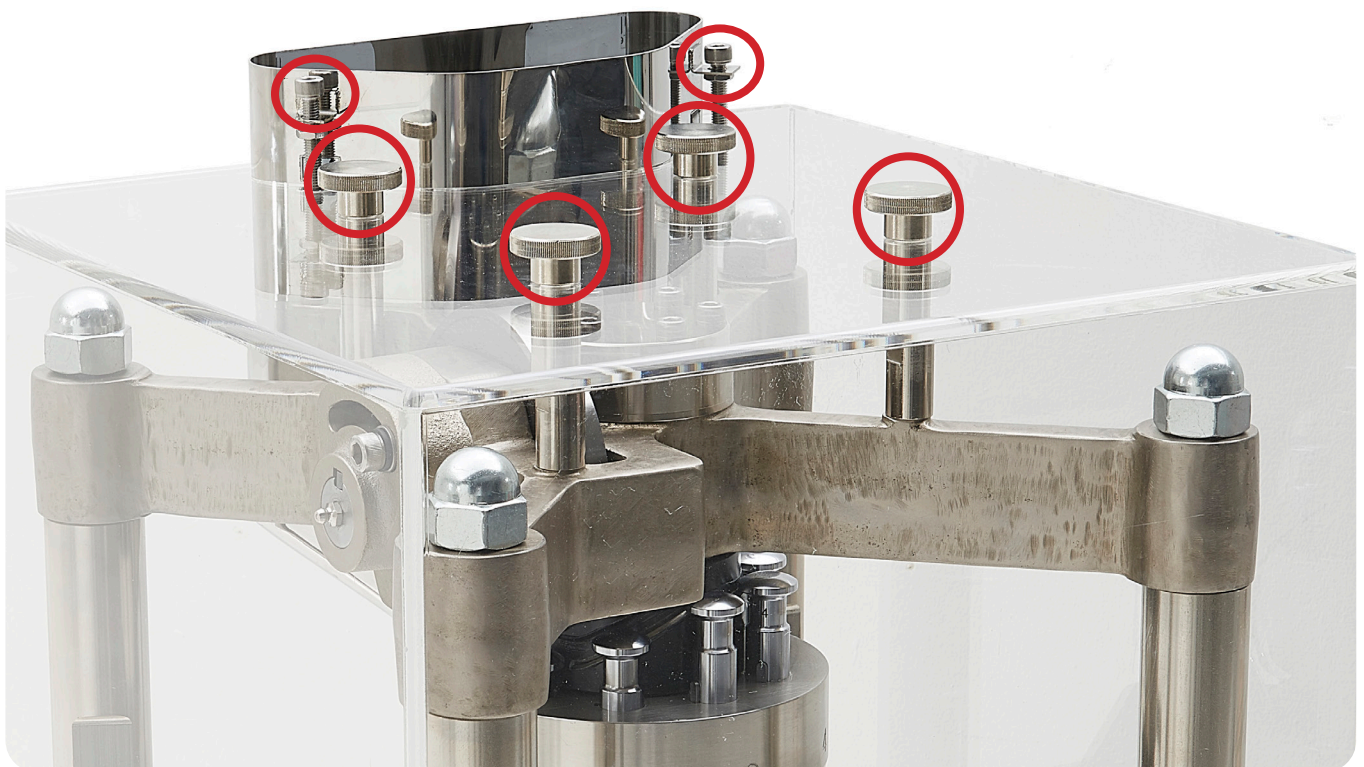

Upper Tracking

The Upper Tracking guides the Upper Punches' movement throughout the machine's operation. To see a video of this process on a similar machine, go to <https://www.lfatabletpresses.com/rtp-9-upper-tracking-change>

Tools and Materials Needed

- Set of metric Allen keys with ball ends
- 36 mm socket wrench
- 450 mm adjustable wrench
- New Upper Tracking part
- Disposable latex/rubber gloves (for food grade products and to protect hands from grease)
- Hairnet and/or beard net (food grade products only)
- Sterile shoe covers (food grade products only)



WARNING: To prevent any potential personal injury, ALWAYS unplug the RTP 118[®] from the electrical outlet when replacing parts.

Instructions

Note: Wear latex/rubber gloves (and appropriate food grade attire if applicable) during this process.

Remove the Upper Tracking

1. Lift up the Hopper and loosen the Perspex Casing's top four screws and remove it.



2. Loosen the Fill Tray's Thumb Bolts and remove them by hand.



3. Remove the Fill Tray from the Turret.

4. Remove the right-hand panel door and insert the Handle onto the Drive Belt Pulley socket.



5. Pull the Upper Punch upwards to remove it from the Turret.
6. Rotate the Handle until the next Upper Punch can be removed.



7. Repeat steps 5-6 until all Upper Punches are removed.

8. Remove the four large nuts on the Perspex Support Columns with a socket wrench.



9. Loosen the four set screws on top of the Upper Pressure Cam Housing with an Allen key.



10. Remove the bearings and the bearings' cap.

11. Remove the Upper Pressure Cam Housing from the Perspex Support Columns.

12. Remove the Upper Tracking from the Upper Pressure Cam Housing.

12.1 Note: Use tools such as a flathead screwdriver and mallet to make its removal easier if needed.

13. Remove each of the four Perspex Support Columns by turning them with a 450 mm adjustable wrench.

Replace the Upper Tracking

14. Place the new Upper Tracking and its key in the Upper Pressure Cam Housing.
15. Insert two of the Perspex Support Columns into opposite corners of the Upper Pressure Cam Housing.
16. Insert the Upper Pressure Cam Housing with the two opposite Perspex Support Columns into the machine.
17. Insert the other two Perspex Support Columns into the machine and Upper Pressure Cam Housing.
18. Tighten the Perspex Support Columns with the 450 mm adjustable wrench.
19. Tighten the four large nuts on the Perspex Support Columns with a socket wrench.
20. Reinsert the bearings and the bearings' cap on top of the Upper Pressure Cam Housing.
21. Tighten the four set screws on top of the Upper Pressure Cam Housing with an Allen key.
22. Insert an Upper Punch through the top of the Turret.
23. Place the Upper Punch's head on the new Upper Tracking.
 - 23.1 Note: Be sure that the Upper Punch's head is above the new Upper Tracking to prevent damage.



24. Rotate the Handle until the next Upper Punch can be inserted.
25. Repeat steps 22-24 until all the Upper Punches are inserted into the Turret.
 - 25.1 Note: Manually turn the RTP 118® Turret for a couple of rotations to ensure that the Upper Punches are situated correctly.

26. Remove the Handle from the Drive Belt Pulley.

27. Place the Fill Tray back on the Turret.

27.1 Note: Please refer to the Fill Tray Height adjustment instructions on page 24 for calibration.

28. Tighten the Fill Tray Thumb Bolts back onto the Fill Tray and RTP 118® by hand.

29. Resecure the Perspex Casing and the Hopper.

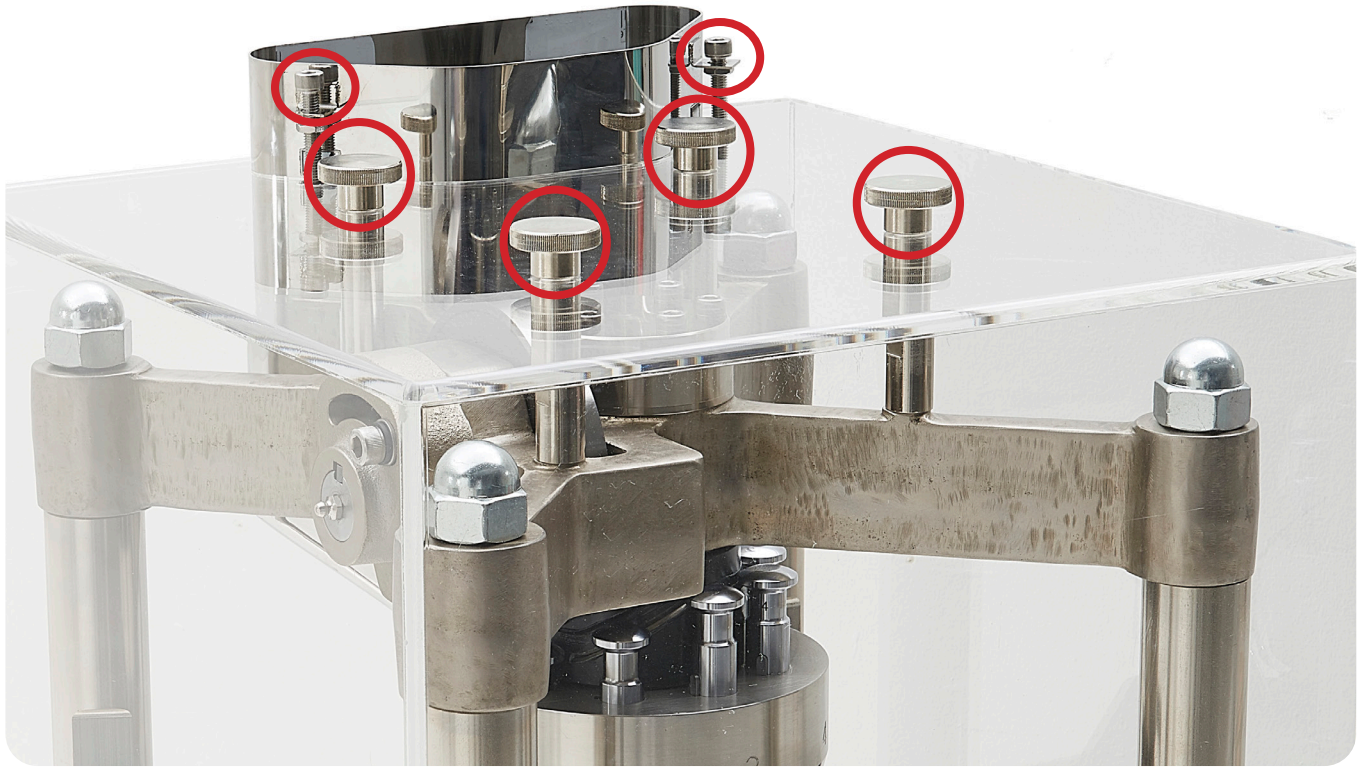

Upper Pressure Cam

The Upper Pressure Cam compresses the Upper Punches to make tablets. These instructions also apply to replacing the Upper Pressure Cam Shaft.

Watch a video to see what a worn Upper Pressure Cam looks like at <https://www.lfatabletpresses.com/rtp-9-inspecting-roller-cams>

Watch a video of Upper Pressure Cam removal and replacement on a similar machine at <https://www.lfatabletpresses.com/rtp9-upper-roller-cam-change-1>

Tools and Materials Needed

- Set of metric Allen keys with ball ends
- 36 mm socket wrench
- New Upper Pressure Cam part
- Disposable latex/rubber gloves (for food grade products and to protect hands from grease)
- Hairnet and/or beard net (food grade products only)
- Sterile shoe covers (food grade products only)



WARNING: To prevent any potential personal injury, ALWAYS unplug the RTP 118® from the electrical outlet when replacing parts.

Instructions

Note: Wear latex/rubber gloves (and appropriate food grade attire if applicable) during this process.

Remove the Upper Pressure Cam

1. Lift up the Hopper and loosen the Perspex Casing's top four screws and remove it.



2. Remove the Upper Pressure Cam Pressure Adjuster with an Allen key.



3. Pull out the Upper Pressure Adjuster from the Upper Pressure Cam Housing.



4. Remove the Upper Pressure Cam Shaft from the Upper Pressure Cam Housing.



5. Remove the Upper Pressure Cam from the Upper Pressure Cam Housing.



Replace the Upper Pressure Cam

6. Insert the new Upper Pressure Cam into the Upper Pressure Cam Housing.

7. Insert the Upper Pressure Cam Shaft into the new Upper Pressure Cam, Upper Pressure Cam Pressure Adjuster, and the top of the Upper Pressure Cam Housing.

7.1 Note: Ensure that the Upper Pressure Cam Shaft's keyed section is in the correct position.



8. Secure the Upper Pressure Cam Pressure Adjuster with an Allen key.

9. Resecure the Perspex Casing and the Hopper.



Troubleshooting

Sometimes unavoidable issues will occur while operating the RTP 118®. Fortunately, there are several methods to remedy these issues.

Common Machine/Part Issues

Symptom	Possible Cause	Possible Solution
Machine freezes or locks up	Grease point areas are dry.	Regularly oil and grease all the Grease Nipples and high friction areas.
	There is excess pressure.	Rotate the Pressure Knob on the left-hand side of machine clockwise.
	There is caking of powder in the machine.	Take apart the Turret and Tooling and clean.
Knocking sounds coming from machine	There is excess pressure.	Rotate the Pressure Knob on the left-hand side of the machine counterclockwise.
	The V Belts are loose.	Replace the V Belts.
	Parts may be loose.	Check the machine's parts and tighten as necessary.
	The Gearbox needs oil.	Check the Gearbox's oil level and lubricate if necessary.
Heavy resistance during production	The high friction areas are either unclean, locked, worn out, or not greased properly.	Apply grease to the Grease Nipple points and all high friction areas and/or clean the machine.
Excess machine vibration	The V Belts are worn.	Replace the V Belts.
	The machine has no anti-vibration pads or they are worn.	Place new anti-vibration pads on the bottom of the machine.
	Parts may be loose.	Check the machine's parts and tighten as necessary.
Excess powder waste	The dry materials are moving too fast.	Lower the rotation speed.
	The Fill Tray is too high or unlevelled.	Adjust the Fill Tray and Fill Tray Scrapers accordingly.
	There is a gap between the Turret and the Machine Base.	Apply NLGI Grade 4 grease to the gap between the Turret and Machine Base.

Symptom	Possible Cause	Possible Solution
Inability to compact materials to tablet form	The Fill Tray is blocked and not enough materials are flowing out.	Check the Fill Tray for a potential clog.
	There is not enough pressure.	Rotate the Pressure Knob on the left-hand side of the machine clockwise.
	The Tooling is damaged.	Remove and replace the Tooling (all Upper Punches, Lower Punches, and Dies)
	There are flowing issues with the mix.	If the machine is able to make tablets with LFA's Firmapress [®] , then the problem is your mix. Adjust your formulation. If still an issue, contact LFA for support.
Powder sticks to the Upper Punch	There is damage to the Tooling or the Tooling's design is causing sticking.	Remove and replace the Tooling (all Upper Punches, Lower Punches, and Dies).
	There are issues with the mix.	Adjust your formulation. If still an issue, contact LFA for support.
Powder sticks to the Lower Punch	There are issues with the mix.	Adjust your formulation. If still an issue, contact LFA for support.

Common Tablet Issues

Symptom	Possible Cause	Possible Solution
Double tablets	Previous tablet did not eject correctly.	Remove the double tablet manually from the Die bore.
	Excess granular materials were placed in the Die, which prevented the ejection of the existing tablet.	Clean the Tooling to remove any excess granular materials and make sure that it is clean and completely dry.
Cracked or broken tablets	There are problems with the formulation of the granules and ingredients.	If the machine is able to make tablets with LFA's Firmapress®, then the problem is your mix. Adjust your formulation. If still an issue, contact LFA for support.
	The Fill Tray is not feeding enough material to be pressed in tablet form.	Adjust the Fill Tray and Fill Tray Scrapers accordingly.
	There is excess pressure.	Please read our article on Capping at https://www.lfatabletpresses.com/articles/tablet-capping
Inconsistent tablet weight	There are flowing issues with the mix.	If the machine is able to make tablets with LFA's Firmapress®, then the problem is your mix. Adjust your formulation. If still an issue, contact LFA for support.
Soft tablets	There is too little punch pressure.	Rotate the Pressure Knob on the left side of the machine counterclockwise.
	There are flowing issues with the mix.	If the machine is able to make tablets with LFA's Firmapress®, then the problem is your mix. Adjust your formulation. If still an issue, contact LFA for support.
Uneven tablets	The Tooling is worn out.	Check the ingredients of your formula before you replace the Tooling.
Broken tablets during ejection	The Ejection Cam is dirty.	Take off the Turret and inspect Ejection Cam and clean if necessary.
	The Ejection Cam is worn.	Replace the Ejection Cam.

De-Jamming the RTP 118®

Some reasons why an RTP 118® might jam are:

- The fill depth is set too low and the pressure is set too high. At its highest punch pressure force, the machine will automatically cut off.
- There is a build up of powder sticking to the Tooling.

Tools and Materials Needed

- Set of metric Allen keys with ball ends
- Disposable latex/rubber gloves (for food grade products and to protect hands from grease)
- Hairnet and/or beard net (food grade products only)
- Sterile shoe covers (food grade products only)



WARNING: To prevent any potential personal injury, ALWAYS unplug the RTP 118® before de-jamming it.

Instructions

Note: Wear latex/rubber gloves (and appropriate food grade attire if applicable) during this process.

Method 1: Lower the Punch Pressure

1. Remove all the excess powder.
2. Rotate the left-hand knob on the console clockwise to its limit.
3. Rotate the right-hand knob on the console clockwise to its limit.
4. Insert the Handle into the Drive Belt Pulley socket.
5. Turn the Handle until the machine turns over.



Cleaning

During the RTP 118®'s operation, excess powder will find its way into parts of the machine, particularly on the Tooling, Fill Tray, Turret, and Upper Tracking. It is important to clean the RTP 118® thoroughly to prevent rusting and cross contamination.

LFA recommends that the machine be cleaned after each operation.

Tools and Materials Needed

- Cleaning brush
- Bagless vacuum
- Turret brush and Die Seat brush from RTP 118® Toolkit
- Toothbrush
- Cleaner (e.g. Member's Mark Commercial Lemon Fresh Disinfectant)
- Sanitizer (e.g. Member's Mark Commercial Sanitizer)
- Set of metric Allen keys with ball ends
- 36 mm socket wrench
- Die Installation/Removal Bar from RTP 118® Toolkit
- Disposable latex/rubber gloves
- Bowl of warm soapy water (nothing abrasive)
- Clean cloths
- Potable water
- Hairnet and/or beard net (food grade products only)
- Sterile shoe covers (food grade products only)



WARNING: To prevent any potential personal injury, ALWAYS unplug the RTP 118® from the electrical outlet when replacing parts.

Instructions

Note: Wear latex/rubber gloves (and appropriate food grade attire if applicable) during this process.

Remove Parts

1. Remove the Hopper, the Perspex Casing, the Fill Tray, and the Tooling
 - 1.1 Note: Please refer to the replace Tooling and Fill Tray instructions on pages 36 and 45 for further guidance.
2. Remove all panel doors.
3. Use a brush to bring powder debris out from hard to reach places.
4. Vacuum the top section of the RTP 118®.
 - 4.1 Note: Ensure that you vacuum inside the top panel where the Turret is positioned.
5. Vacuum the entire areas inside the steel side panel door encasement.
 - 5.1 Note: Be sure to vacuum both levels and all corners of the RTP 118® base.

Note: Before washing the Turret and Die bores, LFA recommends using our Die Seat Cleaner. You can order the Die Seat Cleaner and Insertion Ring on our website at <https://www.lfatablepresses.com/die-seat-cleaner-insertion-ring>



Clean the Parts

6. Take one of the parts removed from the machine and bring it to the bowl of soapy water.
 - 6.1 Note: To ensure that all dirt and debris are removed, wash one part at a time.
7. Take a clean cloth and carefully wash the part thoroughly.
 - 7.1 Note: Use the toothbrush for difficult-to-remove debris. When cleaning tooling, use non-abrasive cleaning equipment such as a soft pipe cleaner and soft cloth.
8. Dry part immediately after it is cleaned and rinsed.
9. Sanitize part with a clean cloth.
10. Lubricate part.
11. Repeat steps 6-10 for each remaining part until they are all clean.



Clean the Turret and the Base

12. Remove any sticky materials from the Turret and Die Seat with the brushes that come in the RTP 118[®] Toolkit.
13. Spray the RTP 118[®] base with the cleaner, particularly in the Turret and the Tooling's location.
14. Rinse the cleaner off with potable water and dry with clean cloth.
15. Sanitize the RTP 118[®] base with a clean cloth.

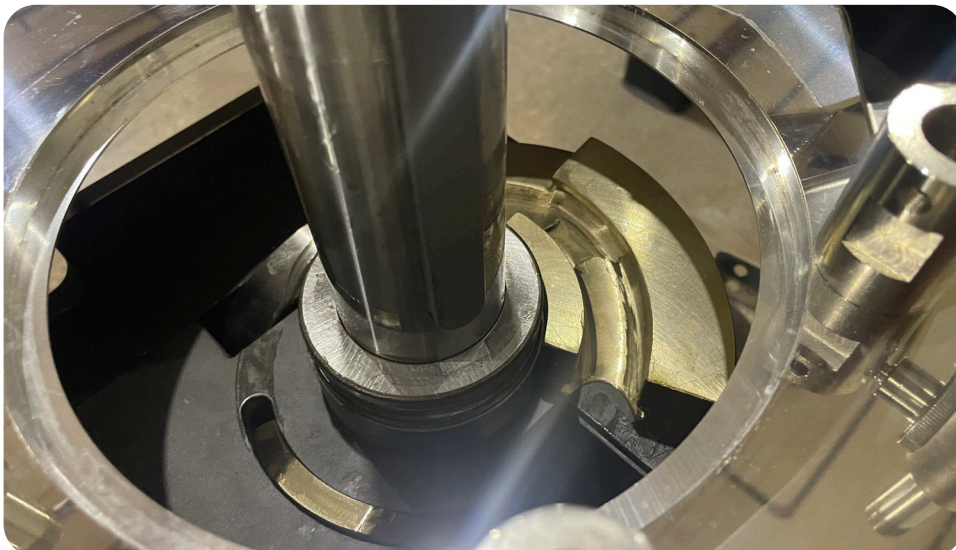

Cleaning Schedule Matrix

Part	Frequency							
	After installing machine	After every use	Before every use	In between products that present a cross contamination risk	Weekly	Monthly	Before placing in storage	After removing from storage
Tooling	Remove from machine	Remove from machine	Install into machine	Remove from machine	N/A	N/A	Remove from machine	Install into machine
Hopper	Remove from machine	Remove from machine	Install into machine	Remove from machine	N/A	N/A	Remove from machine	Install into machine
Perspex Casing	Clean on machine	Clean on machine	Clean on machine	Clean on machine	N/A	N/A	Clean on machine	Clean on machine
Turret and surrounding area	Clean in machine	Clean in machine	Clean in machine	Clean in machine	N/A	N/A	Clean in machine	Clean in machine
Fill Tray and surrounding area	Remove from machine	Remove from machine	Install into machine	Remove from machine	N/A	N/A	Remove from machine	Remove from machine
Upper Pressure Cam Housing (Upper Pressure Cam)	Clean in machine	Clean in machine	Clean in machine	Clean in machine	Clean in machine	Remove from machine	Clean in machine	Clean in machine
Upper Tracking	Clean in machine	Clean in machine	Clean in machine	Clean in machine	Clean in machine	Remove from machine	Clean in machine	Clean in machine
Lower Cam Housing (Lower Pressure Cam)	Clean in machine	Clean in machine	Clean in machine	Clean in machine	Clean in machine	Remove from machine	Clean in machine	Clean in machine
Lower Tracking	Remove from machine	Clean in machine	Clean in machine	Clean in machine	Clean in machine	Remove from machine	Clean in machine	Remove from machine
Motor	Clean in machine	Clean in machine	Clean in machine	Clean in machine	Clean in machine	Remove from machine	Clean in machine	Clean in machine
Gearbox	Clean in machine	Clean in machine	Clean in machine	Clean in machine	Clean in machine	Remove from machine	Clean in machine	Clean in machine
Drive Belt Pulleys	Clean in machine	Clean in machine	Clean in machine	Clean in machine	Clean in machine	Remove from machine	Clean in machine	Clean in machine
Exterior	Clean on machine	Clean on machine	Clean on machine	Clean on machine	Clean on machine	Remove from machine	Clean on machine	Clean on machine
Ejection Chute	Remove from machine	Remove from machine	Install into machine	Remove from machine	N/A	N/A	Remove from machine	Remove from machine

Cleaning Level Key	
Level 1 - Remove powder	
Level 2 - Dry clean with cloth	
Level 3 - Dry clean and re-lubricate if specified in lubrication schedule	
Level 4 - Wet clean and re-lubricate if specified in lubrication schedule	
Remove from machine - Take part out of machine and clean if required. Store it correctly or install back into machine.	
Install into machine - Install part into the machine and make sure that it has been cleaned. If needed, lubricate to the level required.	
Clean on/in machine - Clean the part while in the machine and do not remove it. Make sure that all contact surfaces are clean to the level required.	

This cleaning matrix is intended as a guide only and is not an exhaustive list. All cleaning schedules will need to be adapted to the industry and product, following industry regulations and the material safety data sheets that come with specific products. Please check with your Food Safety Manager/Department, Quality Control Manager/Department, or other relevant internal departments at your company before using.

Storing the RTP 118®

After its thorough cleaning, the RTP 118® needs to be stored in the proper conditions. It is important to store it in an environment in which the machine is safe from rusting. The RTP 118®'s high traction areas and the Tooling need to be lubricated separately before you store them.

Tools and Materials Needed

- Plastic wrapping to cover machine
- Airtight container for Upper Punches, Lower Punches, and Dies (if in storage for more than a week)
- Grease gun
- Lubricant/grease (NSF approved lubricant if machine has a high chance of contact with the food or drug product)
- Disposable latex/rubber gloves (for food grade products and to protect hands from lubricant)
- Hairnet and/or beard net (food grade products only)
- Sterile shoe covers (food grade products only)

Instructions

Note: Wear latex/rubber gloves (and appropriate food grade attire if applicable) during this process.

Lubricating the Tooling

If you are not using the machine for more than a week, store the Tooling in an airtight container (like the one pictured below) and cover it with lubricant to prevent rust formation. If not, simply lubricate each part of the Tooling, particularly the heads and barrels of the Upper and Lower Punches, and reinsert it back into the machine.



LFA's Rotary Tooling Case provides storage and is perfect for transport and protection. Order at <https://www.lfatabletpresses.com/rotary-tooling-case>

Lubricating the Grease Points and High-Traction Parts

1. Open the left and right side panel doors.
2. Lift up the Hopper and loosen the Perspex Casing's bolts and remove it.
3. Lubricate the Lower Cam Roller Shaft's grease nipple with a grease gun.



4. Lubricate the Upper Pressure Cam Shaft's grease nipple with a grease gun.

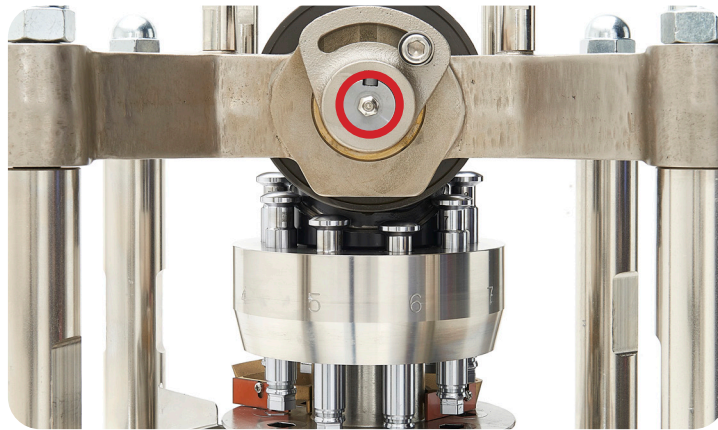

5. Rub grease on the Pressure Adjustment Gear.
6. Lubricate the Fill Adjustment Gear with a grease gun.

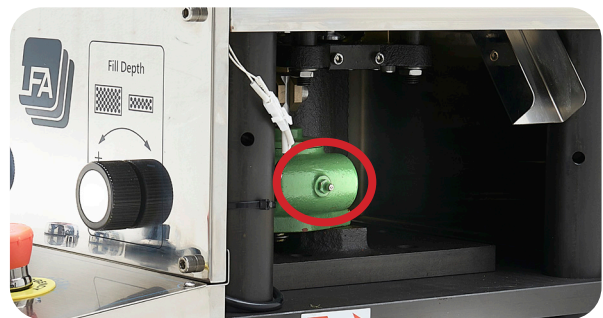

Environmental Conditions

It is important that the environment in which you store the RTP 118[®] has the appropriate temperature and relative humidity levels. These two environmental factors can potentially cause the machine to rust and/or cause the tablets to have a lower quality. The table below shows the acceptable temperature and relative humidity levels:

Machine	Temperature		Humidity
	°C	°F	
RTP 118 [®]	18-24	64-75	45-65% RH

Appendix

Glossary

Term	Definition
API/Active Pharmaceutical Ingredient	Any substance or mixture of substances used that is an active ingredient in the drug product.
Binding agent	See excipient.
Dies	The part of the Tooling that makes up the hole in which the powder is compressed and shaped into a tablet.
Die bore	The cavity inside the middle of the Die.
Die table	The area on the Turret in which the Dies are inserted.
Ejection height	The height at which the Lower Punch is lifted to for a tablet's ejection from the machine.
Excipient	An inactive substance that serves as the vehicle or medium for a drug or other API.
Fill depth	The amount of space that the powder can flow into in the Die.
Formulation	Powder mix of the excipient and the API that is compressed to make tablets.
Granular material	See Formulation.
Kilonewton (kN)	The force to accelerate a mass of 1 kg at a constant 1 m per second. The RTP range's pressure is measured in this unit.
Punches	The Upper Punch and Lower Punch have concave endings in the shape of the desired tablet. When the punches meet, they compress the powder between.
Punch pressure	The adjustable amount of force that is used to press tablets.
RTP	LFA trademarked term for rotary tablet press.
Tooling	Enables a tablet press to form tablets. It consists of Dies, Upper Punches, and Lower Punches.

Description of RTP 118® Parts

Lower Punch and Die Removal Plate

(#DQC0027)

The Lower Punch and Die Removal Plate can be removed to take out/insert the Lower Punches and Dies from/into the Turret.



Tooling

The Tooling consists of the Dies, the Upper Punches, and the Lower Punches. They all work as a set and compress the powder into tablets.

Order at <https://www.lfatabletpresses.com/products/tablet-press-tooling>



Fill Tray Scrapers (#DQC0007)

The Fill Tray Scrapers (2) help keep the powder flowing into the Dies' bores and aid in tablet ejection.

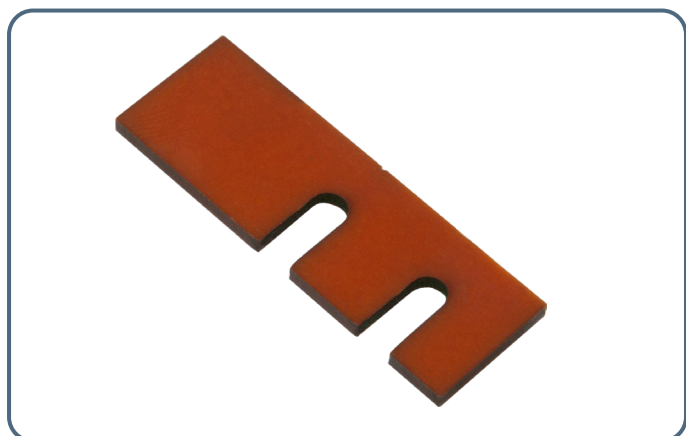

Fill Tray Height Adjusters (#DQB0002)

The Fill Tray Height Adjusters move the Fill Tray's position in proximity to the Turret, which affects powder flow.



Handle (#AEC0052) and Handle Crank (#DQA0032)

The Handle can be attached to the Gearbox and is used to manually operate the RTP 118®.



Upper Pressure Cam Shaft (#DQC0045)

The Upper Pressure Cam Shaft connects the Upper Pressure Cam to the Upper Pressure Cam Housing.



Adjustment Knob Linkages (#DQC0042)

The Adjustment Knob Linkages fit into the Fill Depth Adjustment and Pressure Sensor Dial, which are then turned by the Fill Depth Knob and Pressure Knob.



Pressure Sensor Dial (#DQC0046) and Housing (#DQC0031)

Whenever the Pressure Knob is turned, the Pressure Sensor Dial and Housing moves the Lower Pressure Cam to increase or decrease pressure.



Pressure Knob and Fill Depth Knob
(#DQC0043)

These knobs are used to adjust the pressure and the fill depth. They are located at the front of the control console.



Fill Tray (#DQC0006)

The Fill Tray helps channel the dry materials into the Dies' bores and also pushes the tablets out of the way and into the Ejection Chute.



Hopper (#DQC0040)

The Hopper contains the powder and allows it to flow onto the Fill Tray and into the Dies' bores.



Upper Tracking (#DQC0013)

The Upper Tracking holds the Upper Punches and guides their movement through the Turret.



Fill Cam Adjustment (#DQC0004)

The Fill Cam Adjustment holds the Fill Cam and moves it for adjustments.

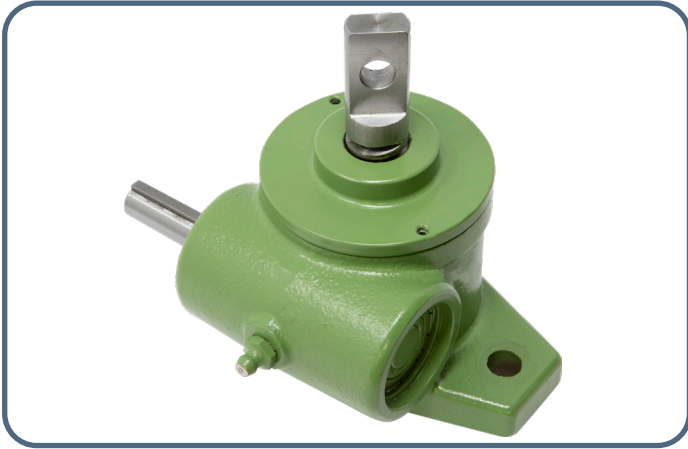

Perspex Support Columns (#DQC0025)

The Perspex Support Columns hold up the Upper Pressure Cam Housing.



Perspex Casing (#DQC0039)

The Perspex Casing covers the upper section of the RTP 118® to prevent cross-contamination and personal injury (Handles not included).



Upper Pressure Cam Housing (#DQC022)

The Upper Pressure Cam Housing contains the Upper Pressure Cam and the Perspex Support Columns.

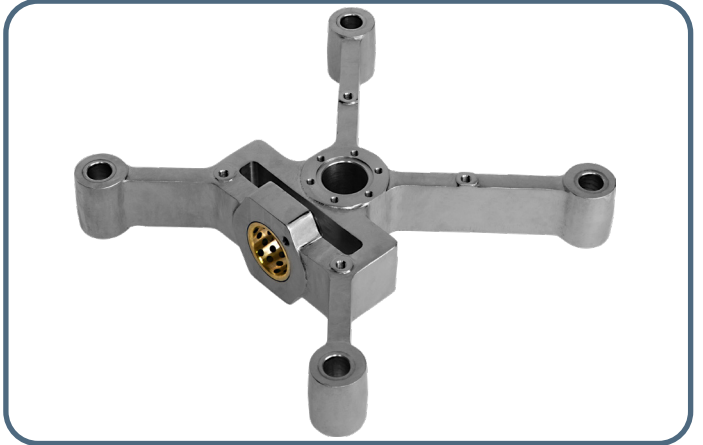

Perspex Casing Handle (#DQC0053)

The Perspex Casing Handle is used to help remove the Perspex Casing.



List of Electrical Components

Name of Part	Part Manufacturer	Part Serial Number	Quantity	Link to Manufacturer's Site
Electric Motor 220 V / 240 V	Qin Wei Electric Corp	4P-5HP, F#112, 1p-220V, 60Hz / 4P-5HP, F#112, 1p-240V, 50Hz	1	Qin Wei Electric Corp
VFD	Adlee	MS2-137	1	Adlee
Terminal Block	Wago	2002-1201	11	Wago
Variable Speed Dial	Guanghua Electronic Mall/Dunhua Electronic Materials Co., Ltd.	VR10T-001	1	Guanghua Electronic Mall/ Dunhua Electronic Materials Co., Ltd.
Variable Speed Dial Steel Plate	Guanghua Electronic Mall/Dunhua Electronic Materials Co., Ltd.	VR10T-001L	1	Guanghua Electronic Mall/ Dunhua Electronic Materials Co., Ltd.
Potentiometer	TOCOS	RV24YN-20S-B103	1	TOCOS
Fuse Socket with Light	Shan Ho	SFJKN-1 AC110~220V	1	Shan Ho
Fuse	Eaton	10 * 38 2A	1	Eaton
Circuit Breaker	Fuji Electric	BC62E0C-020	1	Fuji Electric
3 Phase AC Socket	Guanghua Electronic Mall/Dunhua Electronic Materials Co., Ltd.	6214CAP	1	Guanghua Electronic Mall/ Dunhua Electronic Materials Co., Ltd.
3 Phase AC Switch	Shan Ho	SC-88-3P	1	Shan Ho
Emergency Stop	Rockwell Automation	800FM-MT44/ALM/X02	1	Rockwell Automation
Stop Button	Rockwell Automation	800FM-L34?ALM/X01/ N3R	1	Rockwell Automation
Run Button	Rockwell Automation	800FM-LF3/ALM/X10/ N3G	1	Rockwell Automation
Perspex Sensor	Omron	TL-N5MY1	1	Omron
Door Sensor/Switch	Omron	Z-15GW22614-B OMI	1	Omron
Reed Switch	Cashtec Electronic Co., Ltd.	PS8-30	1	Cashtec
Contactors	Fuji Electric	SW-4 1/3H 12A AC110V 1A	1	Fuji Electric
12AG 4Amp Cord	KSS	AG-12-4A	1	KSS
16AG Cable	KSS	AG-16	1	KSS
Cable Rubber Grommet	KSS	GM-0705	1	KSS
Fan Guard	Sunon	DP201A/2123HBT.GN AC220V	1	Sunon
Relay	Omron	MY2N-GS AC200/220 BY OMZ	1	Omron
LED Light (Indicator)	Guanghua Electronic Mall/Dunhua Electronic Materials Co., Ltd.	9815BG(N-701-2-G)	4	Guanghua Electronic Mall/ Dunhua Electronic Materials Co., Ltd.
4" Fan	Sunon	DP201A/2123HBT.GN AC220V	1	Sunon
4" Fan Guard	Sunon	FG-12	1	Sunon
Cooling Fan Power Cord Female Socket	Sunon	4" A2-20 2M	1	Sunon
90 Degree Pressure Sensitive Switch	AVC Industrial Corp	AMC-1L 90°	1	AVC Industrial Corp
Magnet	Cashtec Electronic Co., Ltd.	MAG030A0900-1M000	1	Cashtec Electronic Co., Ltd.
Cement Wire Round Resistor	Guanghua Electronic Mall/Dunhua Electronic Materials Co., Ltd.	SQP20W-320	1	Guanghua Electronic Mall/ Dunhua Electronic Materials Co., Ltd.

Material of Contact Parts

Contact Part	Material
Turret	SUS316
Outer Ejection Chute	SUS304
Hopper	SUS304
Tooling (Upper Punches, Lower Punches, and Dies)	User specified
Fill Tray	Brass alloy
Fill Tray Scrapers	Bakelite

Technical Specifications

Tooling Specification	Euro B
Number of dies	9
Production capacity	32,400/hr
Max diameter of tablet	16 mm (round) 19 mm (irregular)
Max fill depth	17 mm
Thickness of tablet	8 mm
Max pressure	60 kN
Number of filling stations	1
Double layered tablet	No
Kilowatts	3.7 kW
Volts	240 V or 220 V
Hertz	60 or 50
Amps	14.6 or 14.0
Overall size	1200 mm x 670 mm x 675 mm
Dimensions with suggested working clearance	2100 mm x 1570 mm x 1575 mm
Weight	330 kg (approximately 728 lbs)
Floor loading (static)	0.8 kN/m ²

Maintenance Checklist

Before Operation	
<input type="checkbox"/>	Visually inspect the tablet press and the parts.
<input type="checkbox"/>	Ensure all locking nuts are tight.
<input type="checkbox"/>	Visually inspect Grease Nipples and regrease where necessary.
<input type="checkbox"/>	Manually rotate the machine without powders to ensure that it is not jammed
<input type="checkbox"/>	Ensure Handle is removed from the Drive Belt Pulley socket.
<input type="checkbox"/>	Ensure Perspex Casing securely encloses the upper portion of machine.
<input type="checkbox"/>	Visually inspect electrical wires for any damage.
During Operation	
<input type="checkbox"/>	Tune the tablet press until the tablet size and weight are correct
<input type="checkbox"/>	Listen for irregular knocking or clicking sounds. If heard, stop operation, release the pressure by rotating the Pressure Knob on the left-hand side of the machine clockwise a few times, and lubricate the machine.
<input type="checkbox"/>	Watch for buildup of powder in front of the Fill Tray. If occurring, either (a) make mix more granular, (b) check the Fill Tray for damage, (c) clear the buildup, or (d) adjust the Fill Tray and/or Hopper.
<input type="checkbox"/>	Occasionally check the Motor's temperature. If it starts to overheat, turn off the machine, let it cool down, and grease it to ensure smooth operation.
<input type="checkbox"/>	Ensure that the Hopper does not run out of powder.
<input type="checkbox"/>	Weigh five or ten sample tablets to ensure the desired weights, tablet height, and hardness are being met.
<input type="checkbox"/>	Check to see that the Emergency Stop properly works.
After Operation	
<input type="checkbox"/>	Unplug machine and remove all excess powder with a bagless vacuum.
<input type="checkbox"/>	Remove the Perspex Casing, Hopper, Fill Tray, Tooling, Upper Pressure Cam Housing, and Turret and clean the inside of the tablet press.
<input type="checkbox"/>	Wipe down the other surfaces with a damp cloth.
<input type="checkbox"/>	Apply a layer of NSF approved grease to the entire tablet press.
<input type="checkbox"/>	Lubricate all Grease Nipples.
<input type="checkbox"/>	Store Tooling in an airtight box with a small amount of grease.

RTP 118® Euro D Lower Punch Dimensions

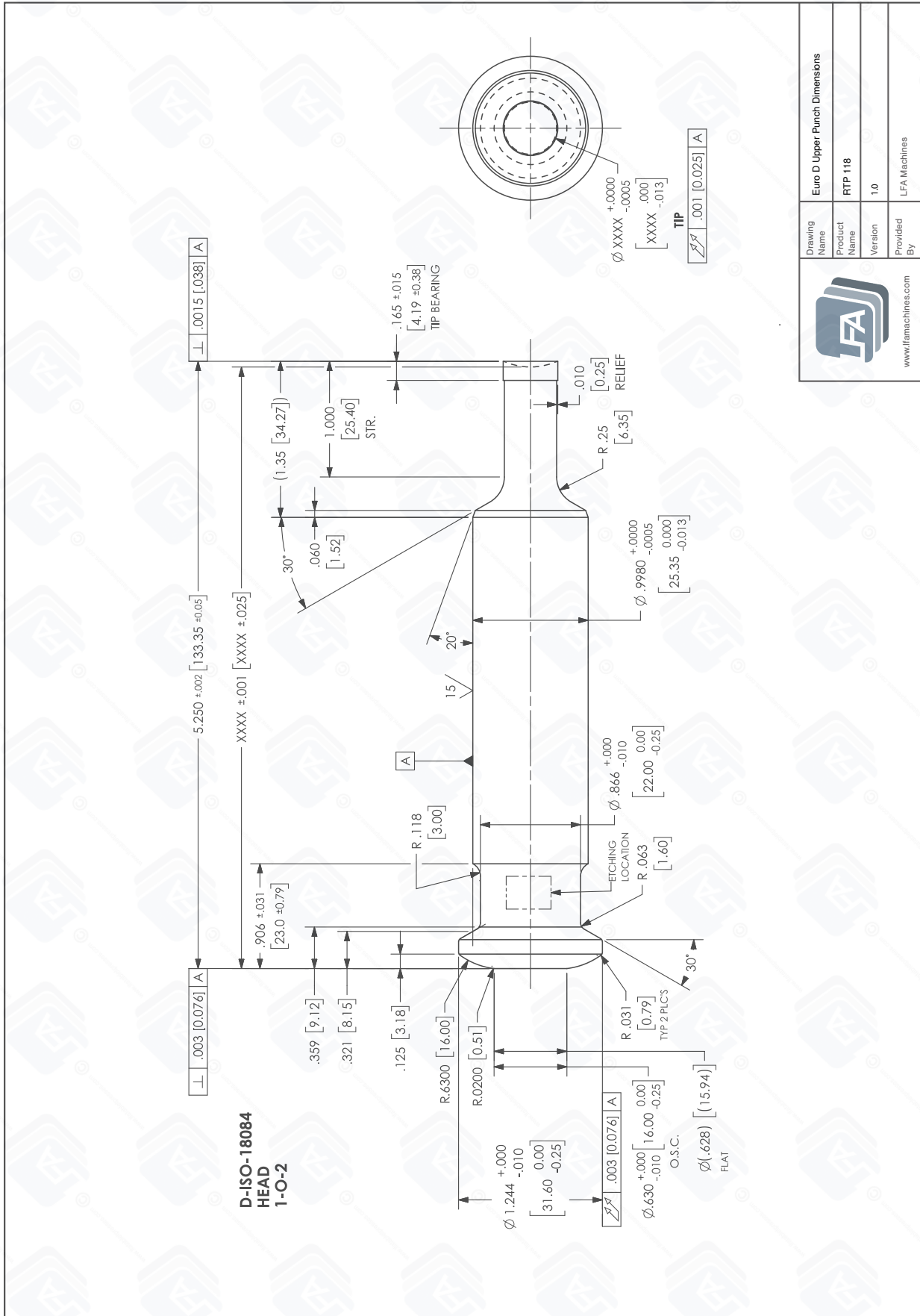

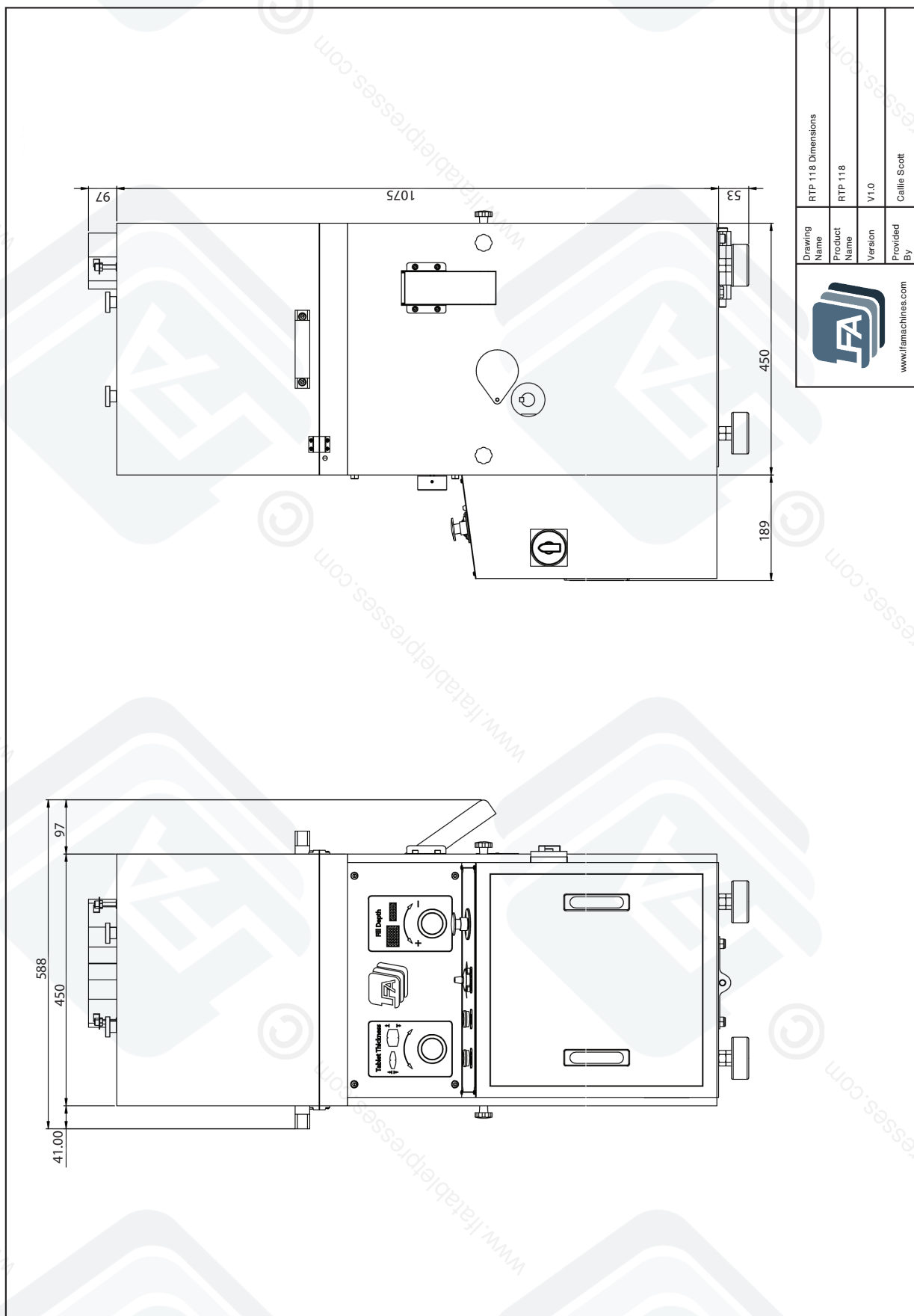

 www.lfamachines.com		Euro D Upper Punch Dimensions	
Drawing Name	RTP 118	Product Name	RTP 118
Version	1.0	Provided By	LFA Machines

RTP 118® Dimensions

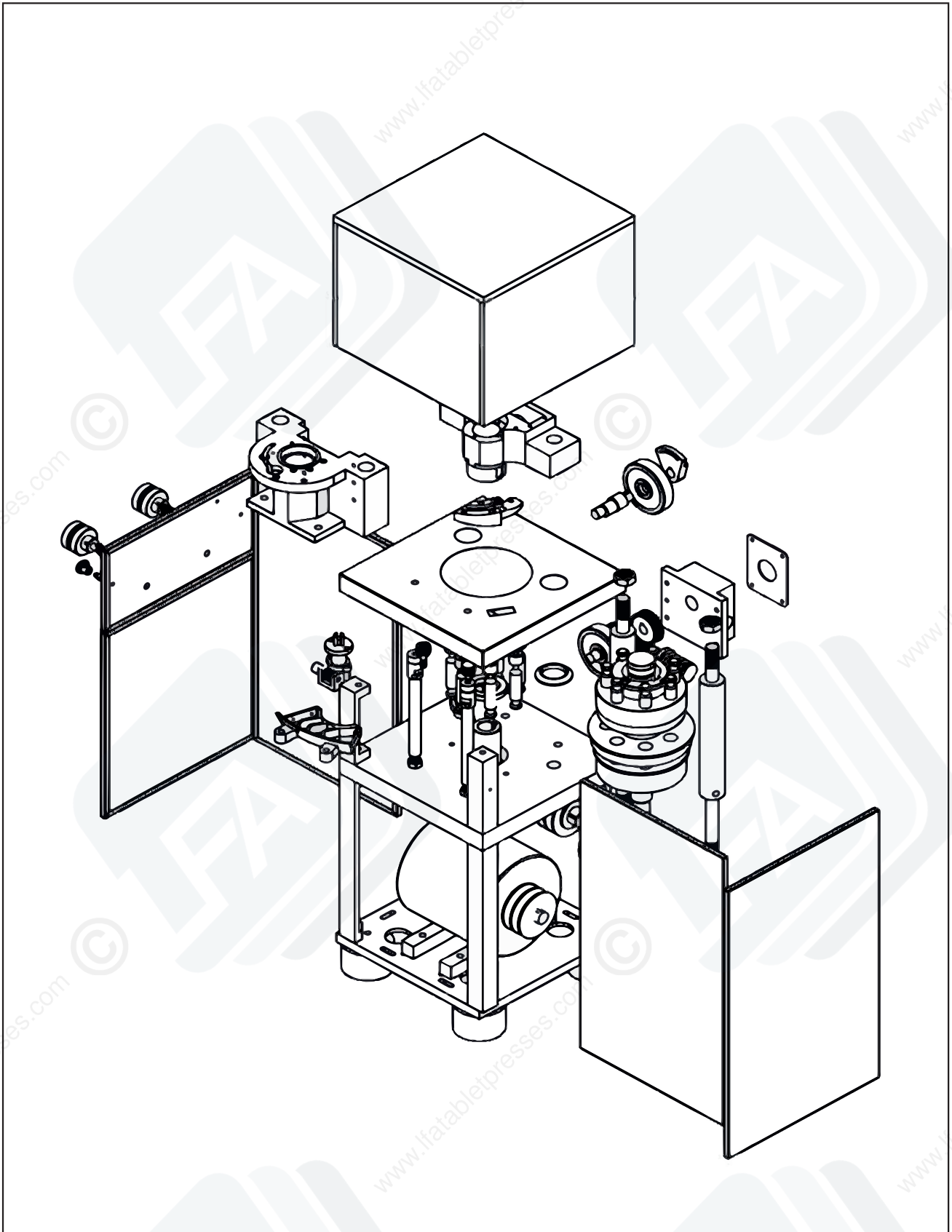

RTP 118® Exploding Diagram



 www.lfamachines.com	Drawing Name	RTP 9 Explosive Diagram
	Product Name	RTP 9
	Version	V1.0
	Provided By	LFA Machines

RTP 118® Wiring Diagram

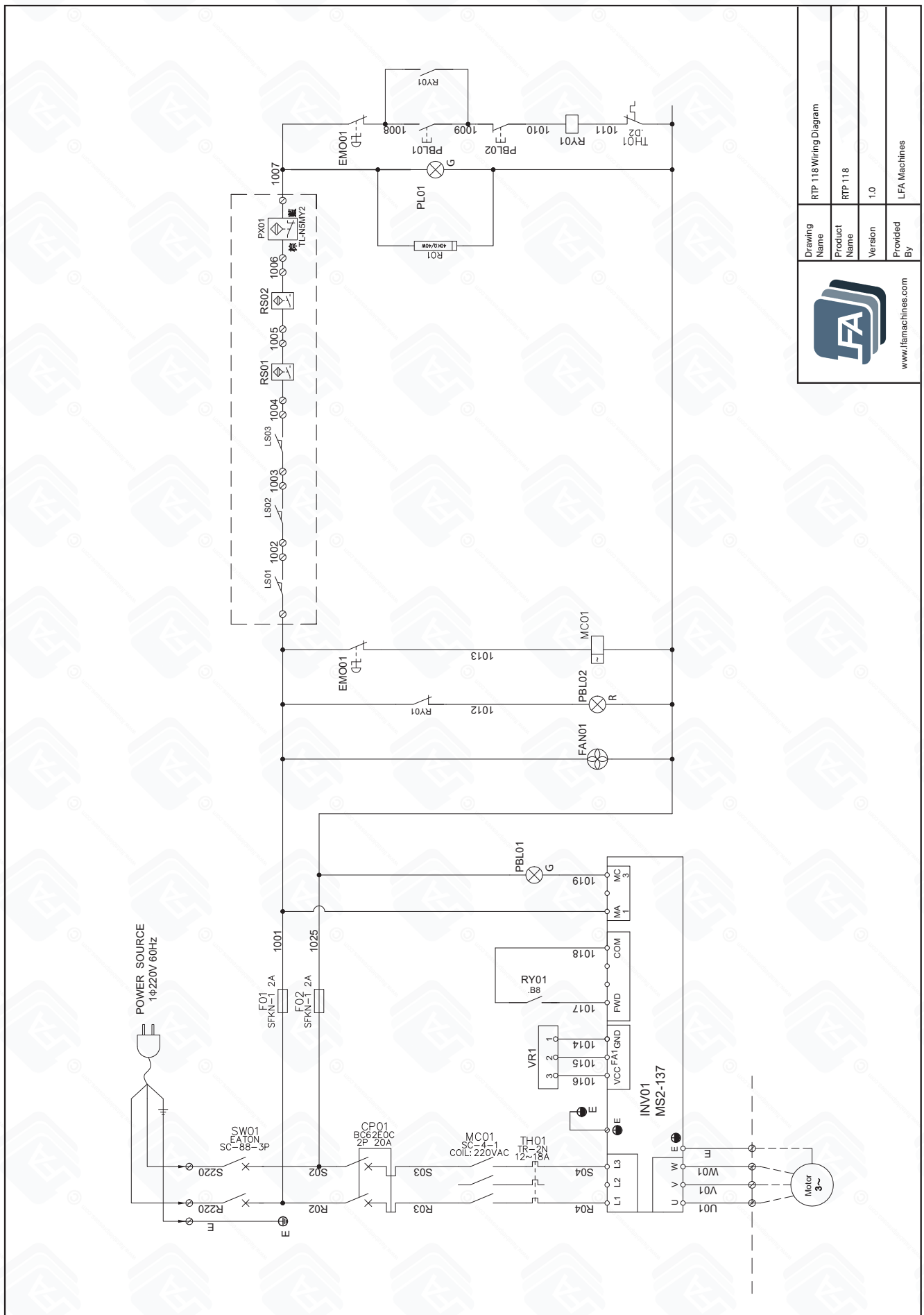

Drawing Name	RTP 118 Wiring Diagram
Product Name	RTP 118
Version	1.0
Provided By	LFA Machines



RTP 118® Exploding Diagram

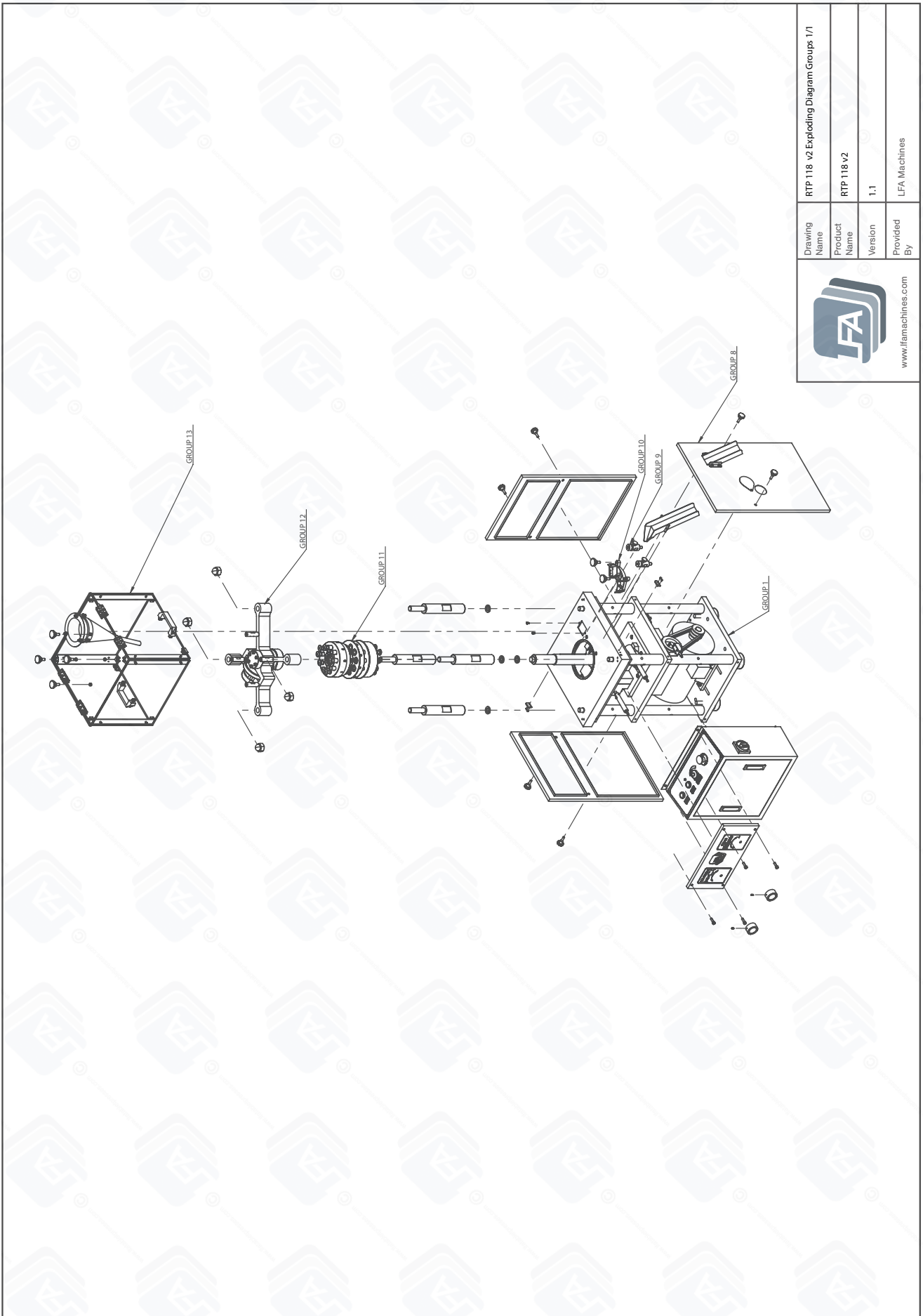

 www.lfamachines.com	Drawing Name	RTP 118 v2 Exploding Diagram Groups 1/1
	Product Name	RTP 118 v2
	Version	1.1
	Provided By	LFA Machines

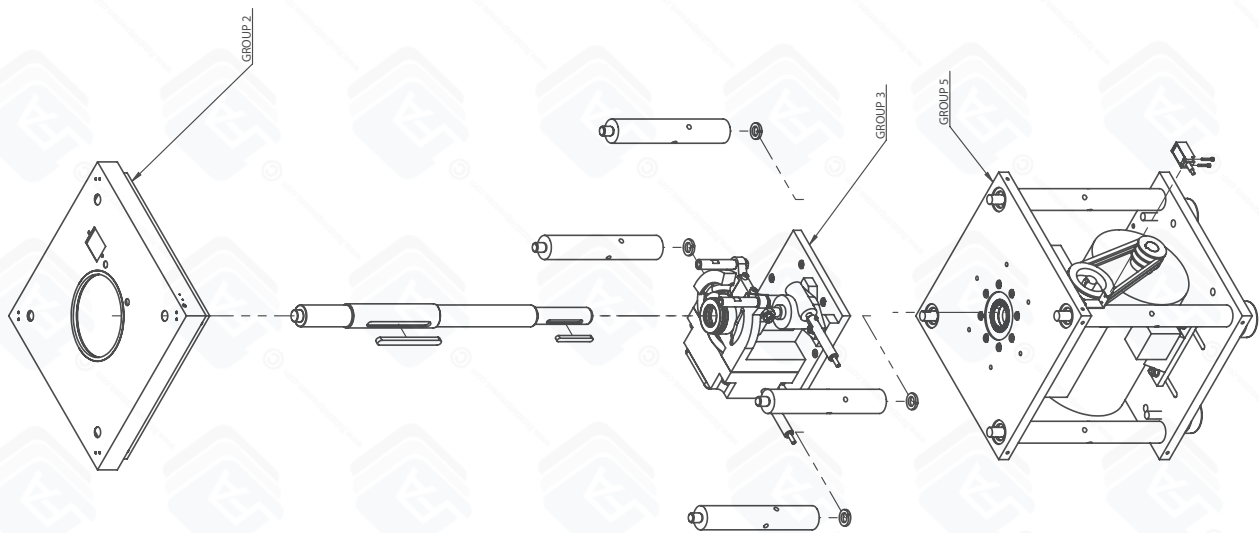

 www.lfamachines.com		Drawing Name	RTP 118 v2 Exploding Diagram Group 1
Product Name	RTP 118 v2	Version	1.1
Provided By	LFA Machines		

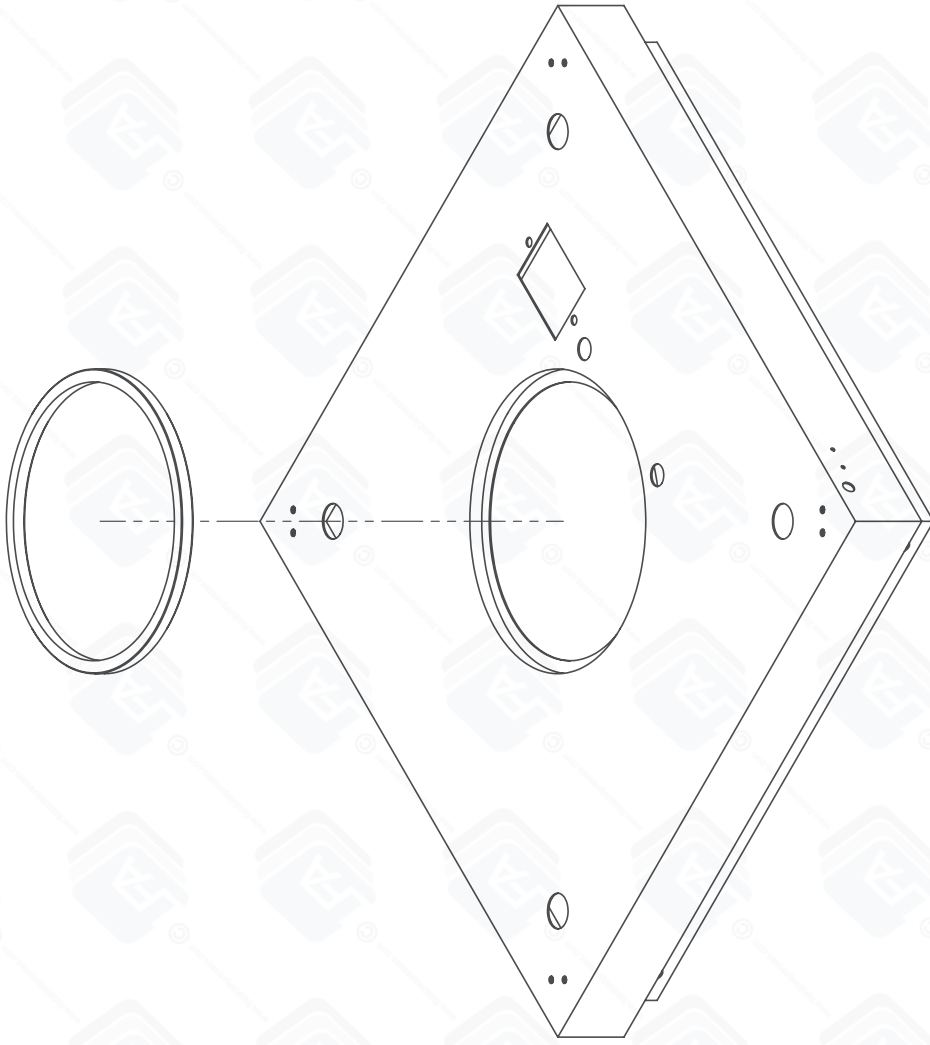

 www.lfamachines.com		Drawing Name	RTP 118 v2 Exploding Diagram Group 2
Product Name	RTP 118v2	Version	1.1
Provided By	LFA Machines		

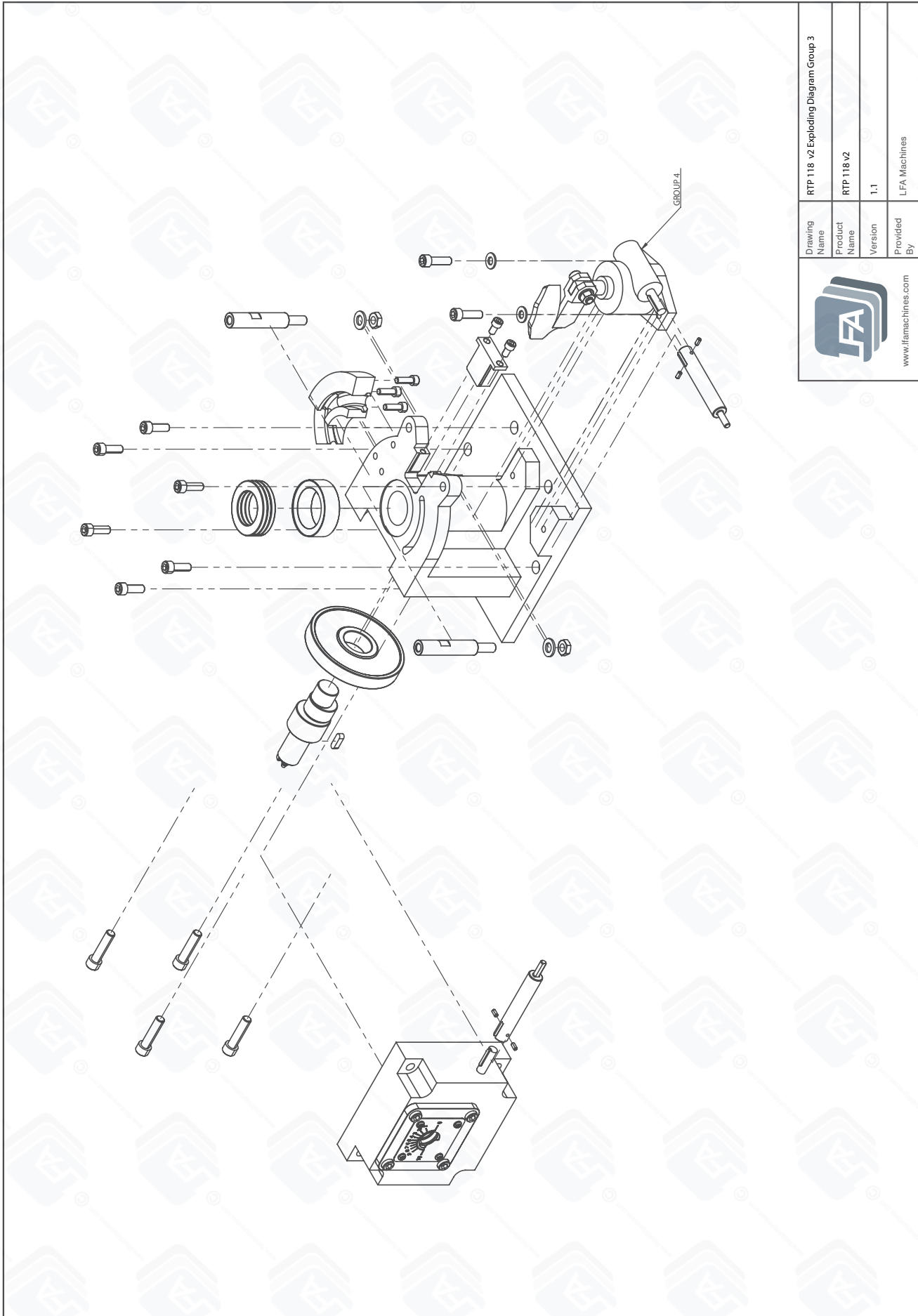

RTP 118 v2 Exploding Diagram Group 3			
Drawing Name	Product Name	Version	Provided By
	RTP 118 v2	1.1	LFA Machines
			www.lfamachines.com

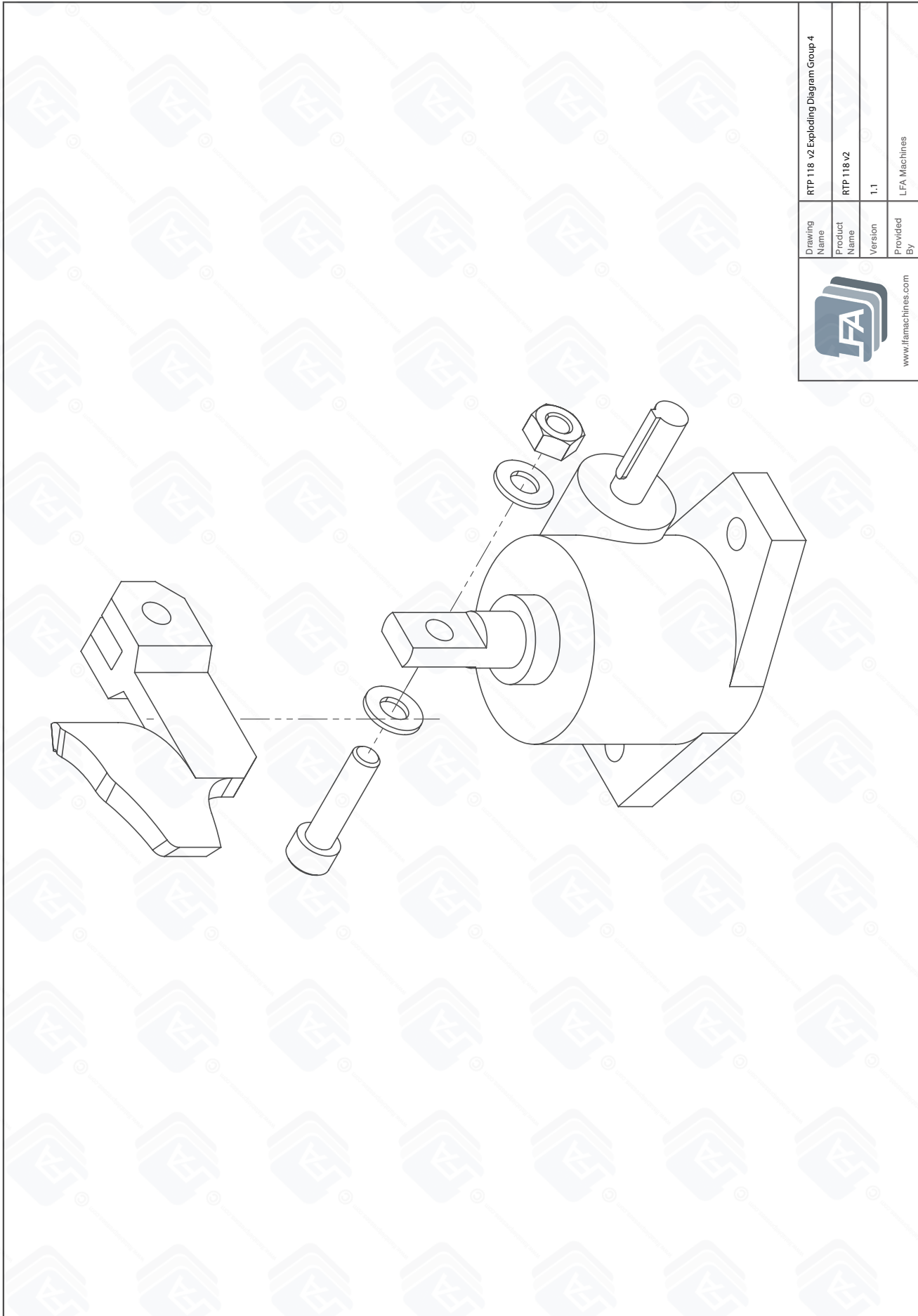

 www.lfamachines.com	Drawing Name	RTP 118 v2 Exploding Diagram Group 4		
	Product Name	RTP 118 v2		
	Version	1.1		
	Provided By	LFA Machines		

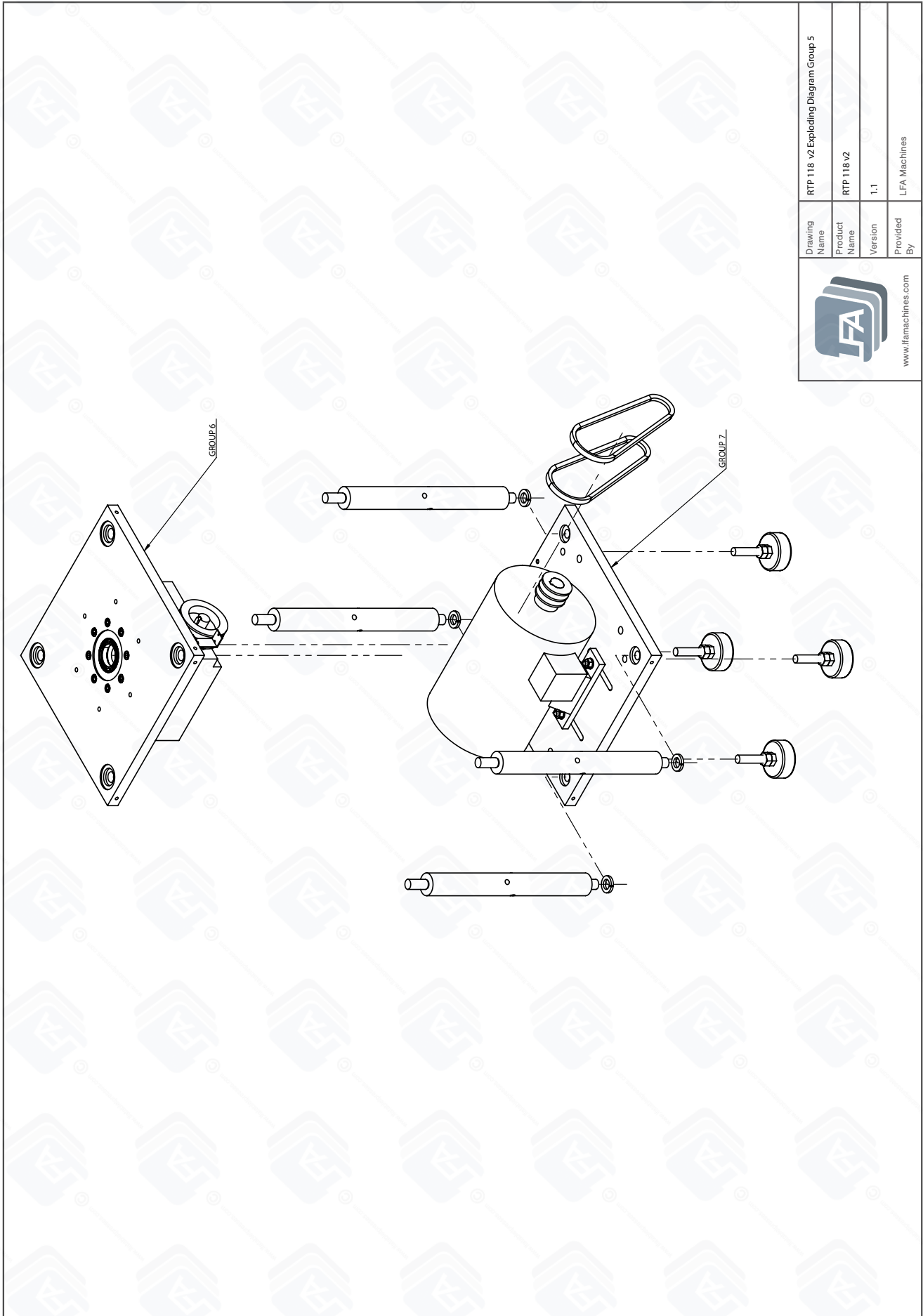

 www.lfamachines.com		Drawing Name	RTP 118 v2 Exploding Diagram Group 5
Product Name	RTP 118 v2	Version	1.1
Provided By	LFA Machines		

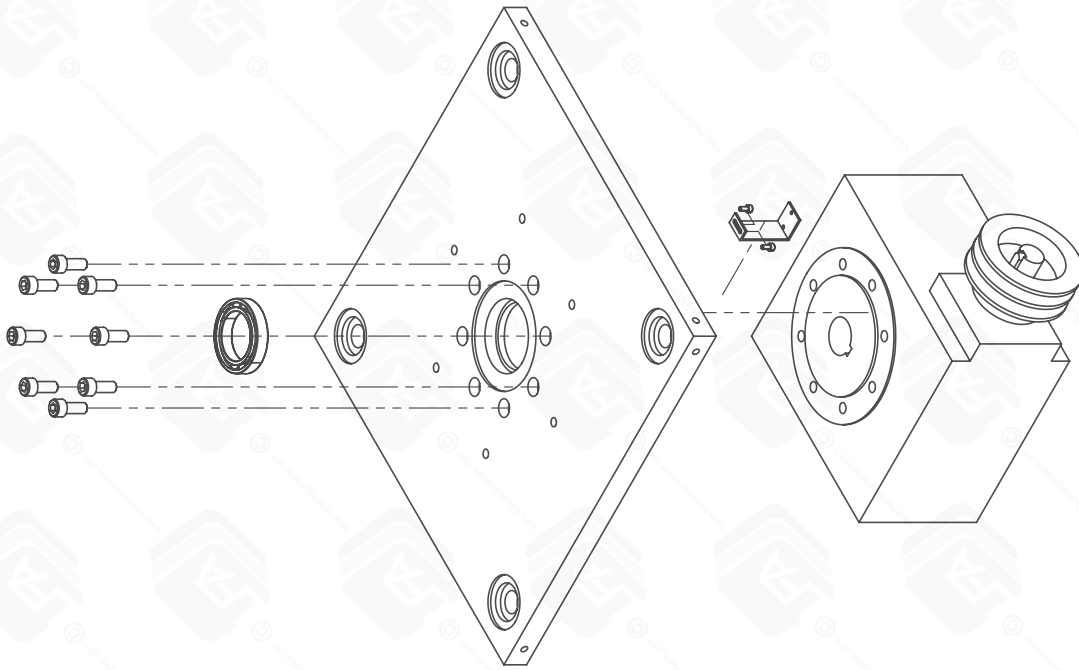

RTP 118 v2 Exploding Diagram Group 6			
Drawing Name	Product Name	Version	Provided By
	RTP 118 v2	1.1	LFA Machines
		www.lfamachines.com	

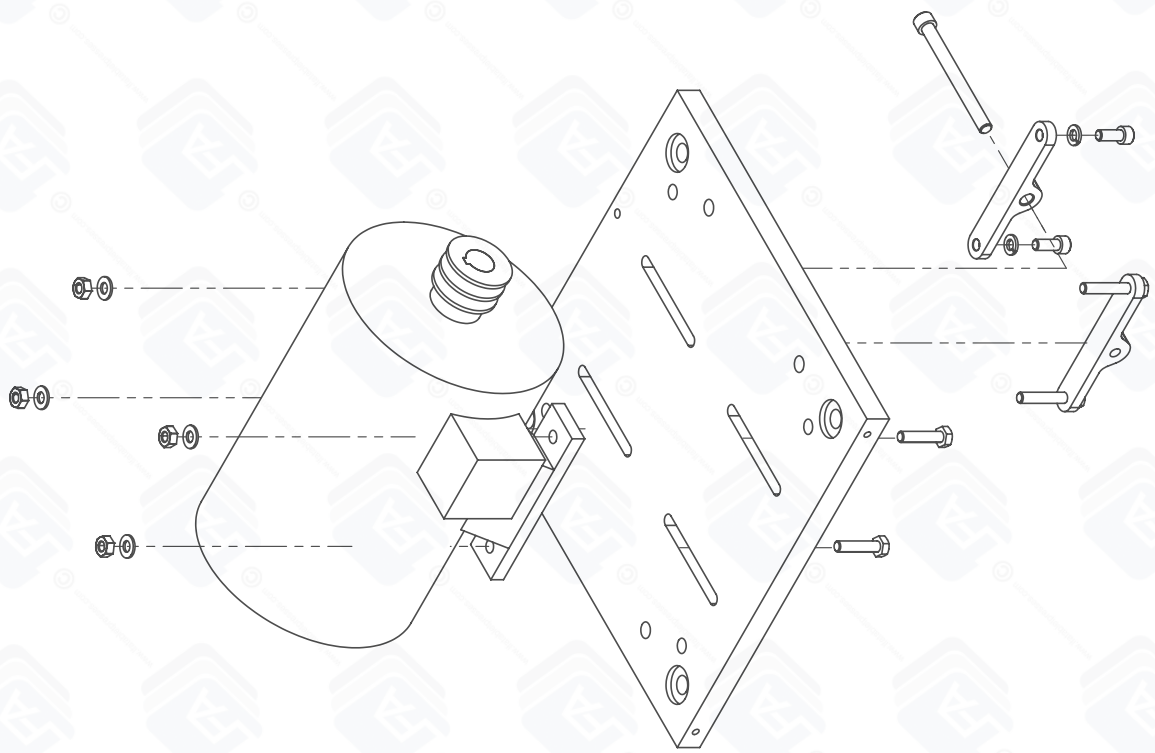

 www.lfamachines.com		Drawing Name	RTP 118 v2 Exploding Diagram Group 7
Product Name	RTP 118 v2	Version	1.1
Provided By	LFA Machines		

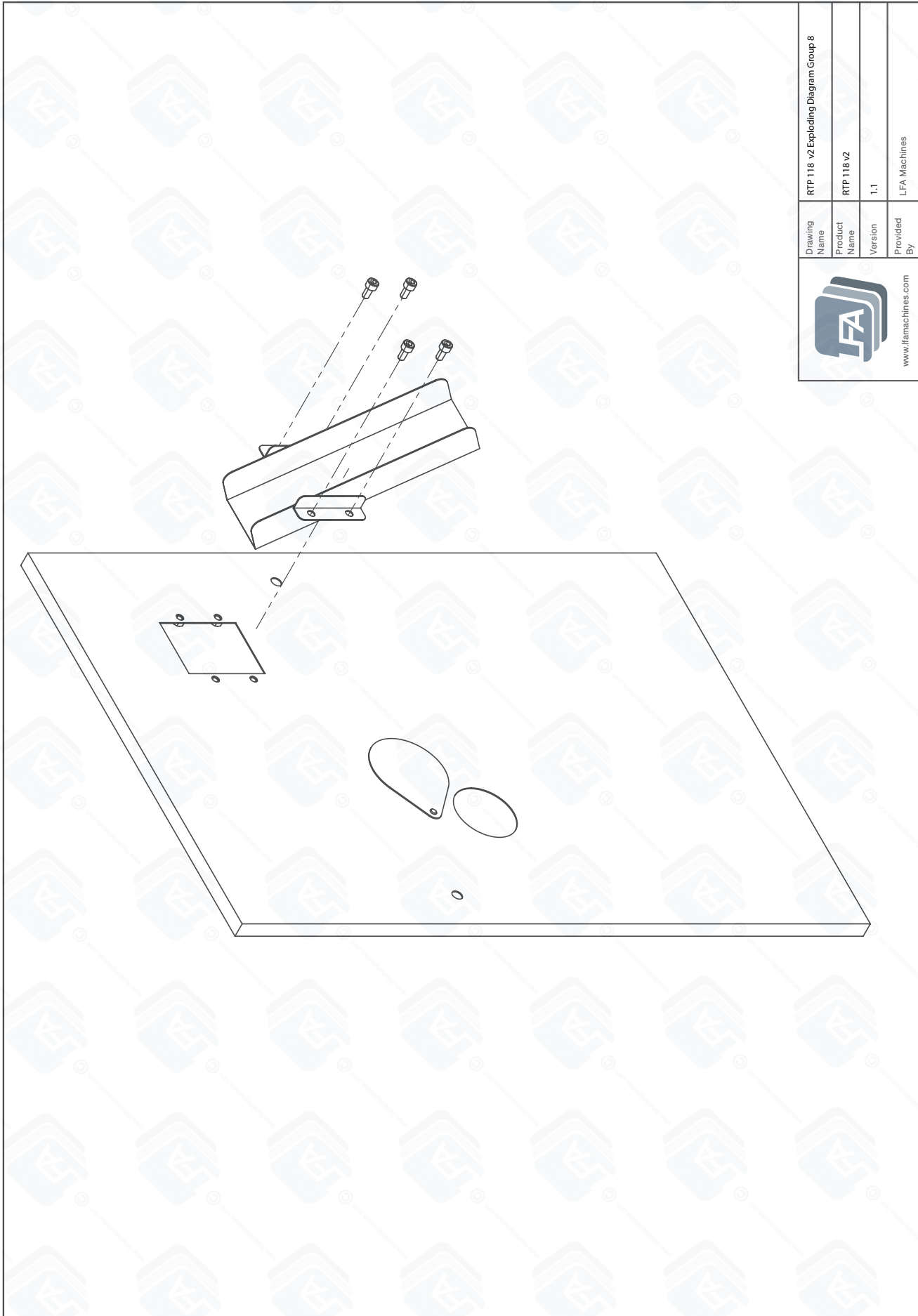

Drawing Name		RTP 118 v2 Exploding Diagram Group 8	
Product Name		RTP 118 v2	
Version		1.1	
Provided By		LFA Machines	



www.lfamachines.com

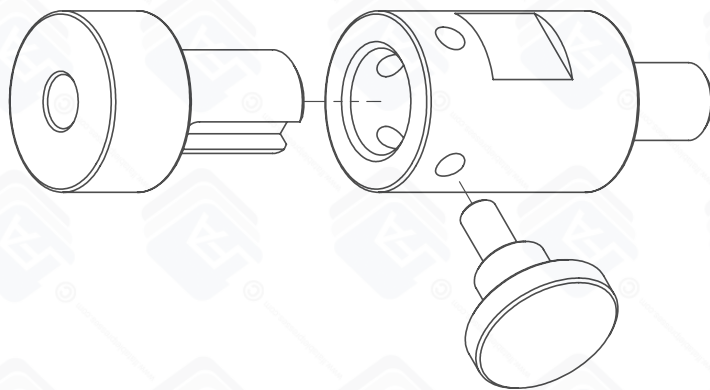

 www.lfamachines.com	Drawing Name	RTP 118 v2 Exploding Diagram Group 9		
	Product Name	RTP 118 v2		
	Version	1.1		
	Provided By	LFA Machines		

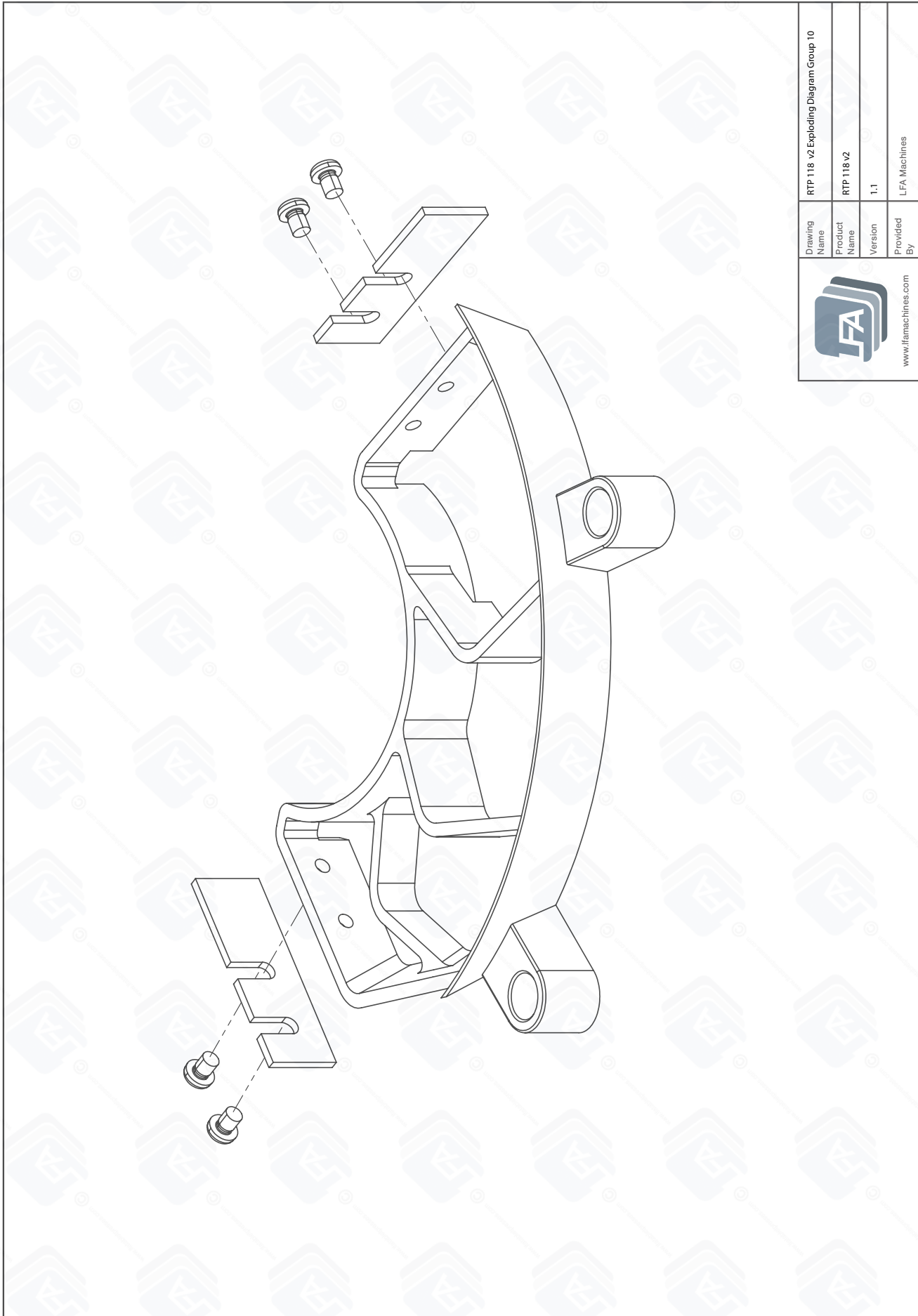

Drawing Name	RTP 118 v2 Exploding Diagram Group 10		
Product Name	RTP 118 v2		
Version	1.1		
Provided By	LFA Machines		



www.lfamachines.com

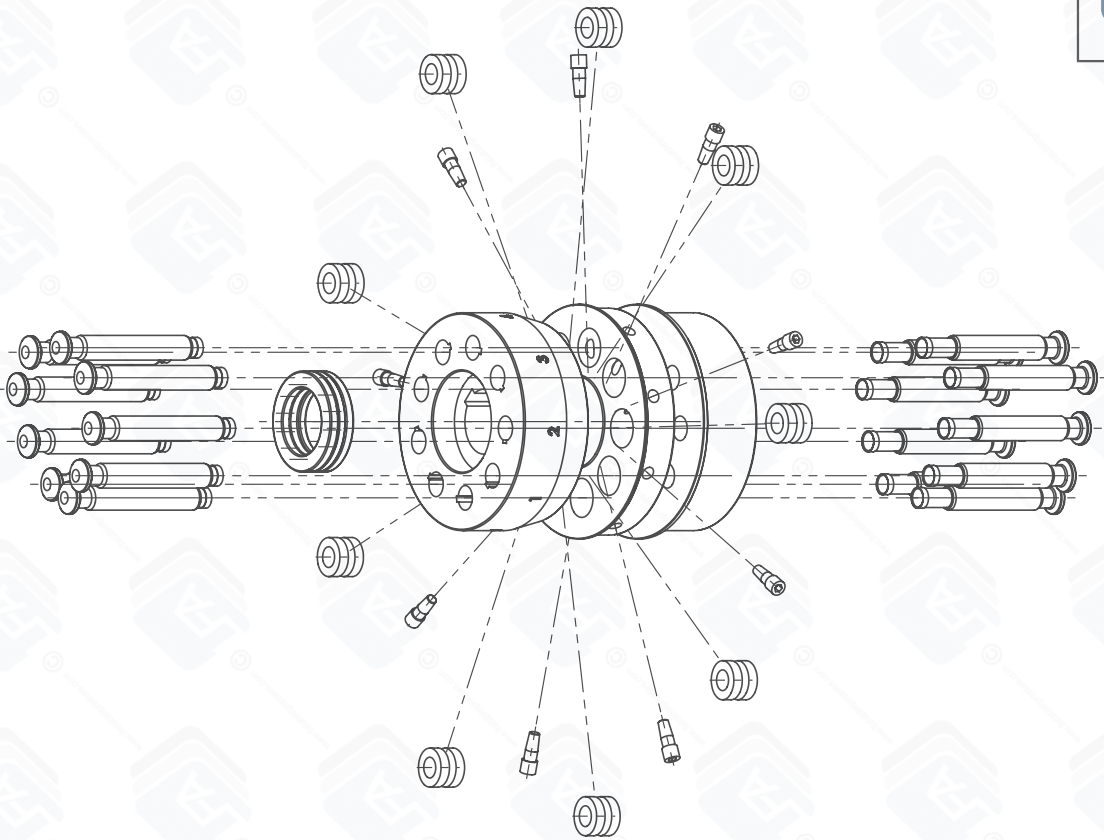

RTP 118 v2 Exploding Diagram Group 11	
Drawing Name	RTP 118 v2
Product Name	1.1
Version	LFA Machines
Provided By	



www.lfamachines.com

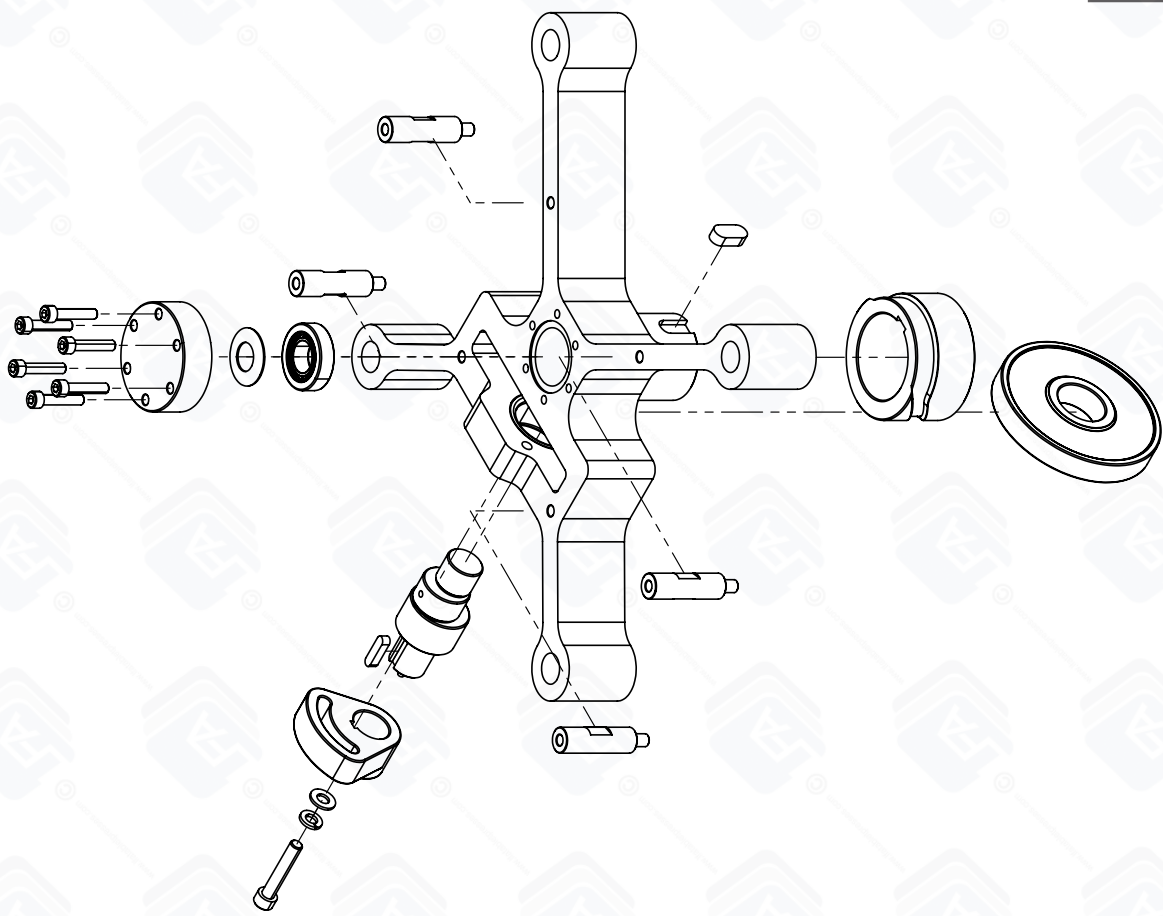

 www.lfamachines.com		Drawing Name	RTP 118 v2 Exploding Diagram Group 12
Product Name	RTP 118v2	Version	1.1
Provided By	LFA Machines		

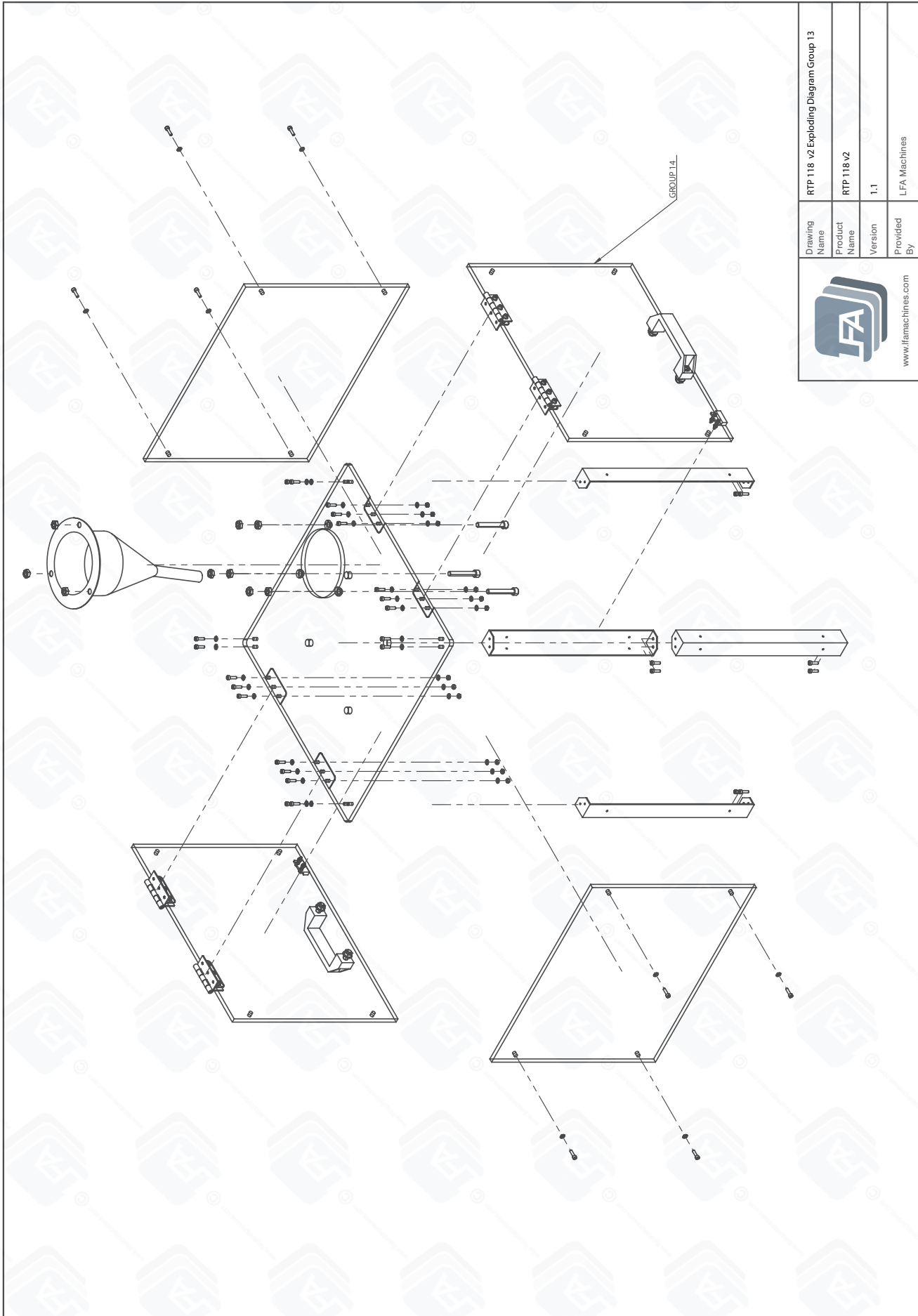

Drawing Name	RTP 118 v2 Exploding Diagram Group 13
Product Name	RTP 118 v2
Version	1.1
Provided By	LFA Machines



www.lfamachines.com

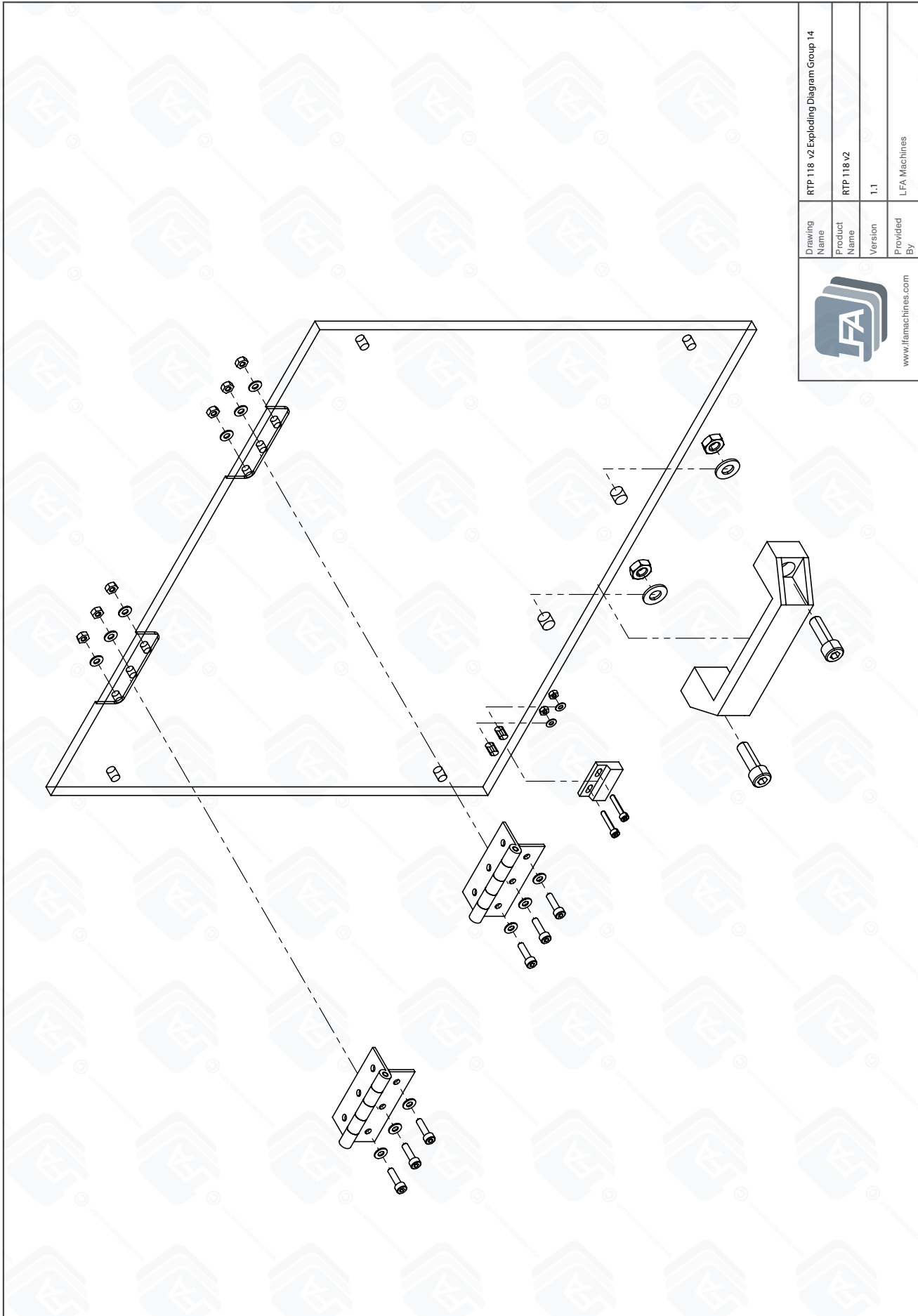

 www.lfamachines.com		Drawing Name	RTP 118 v2 Exploding Diagram Group 14
Product Name	RTP 118 v2	Version	1.1
Provided By	LFA Machines		

Resources

Helpful Links

Warranty

For information regarding the warranty policy of the RTP 118® and other LFA products, please visit <https://www.lfatabletpresses.com/warranty>

LFA Website

In order to aid you in your tablet production, LFA Machines maintains a website that offers a breadth of useful information about the RTP 118® and other tablet presses. You have access to online tools such as the Tablet Mix Calculator to help you in your formulation production and our regularly published articles that cover a whole range of topics about tablet presses and tablet production.

Visit the LFA homepage at <https://www.lfatabletpresses.com>

To create a free member's account, follow this link: <https://www.lfatabletpresses.com/customer/account/create>

LFA Machines YouTube Channel

Our YouTube videos provide you an opportunity to see demonstrations of how to use our tablet presses, common troubleshooting tips, and other LFA products such as capsule fillers and mixers. We regularly upload videos to give you a visual aid that will hopefully support you in your tablet production efforts. To watch our videos, visit <https://www.youtube.com/channel/UCwtbcwja77ai7vX2o34FUkQ>

LFA Machines Social Media

Social media is a great way to keep yourself updated on new developments and exciting things happening at LFA Machines. The list below contains our current social media pages:

Twitter: @lfatabletpress

Facebook: <https://www.facebook.com/lfatabletpresses>

LinkedIn: <https://www.linkedin.com/company/lfa-machines-oxford-ltd/>

Contact Us

UK

LFA Machines Oxford Ltd
Unit 4B Rowood Estate
Murdock Road
Bicester, Oxfordshire OX26 4PP
+44 (0) 1869 250 234
support.uk@lfamachines.com
Monday-Friday
9AM-5PM GMT

USA

LFA Machines DFW, LLC
6601 Will Rogers Blvd
Fort Worth, TX 76140
+1 (682) 312 0034
support.usa@lfamachines.com
Monday-Friday
8AM-6PM UTC (Central)

Germany

LFA Machines Düsseldorf GmbH
Business Parc Am Trippelsberg 92
Düsseldorf, North-Rhine
Westphalia 40589
+41 21188250223
verkauf@lfamachines.com

Taiwan

LFA Machines Taiwan Ltd
7F-5, No. 2, Sec. 2 Taiwan Blvd
West District, Taichung City 403
Taiwan
+886 422031790
support.asia@lfamachines.com
Monday-Friday
9AM-5PM GMT+8



LFA MACHINES

Copyright © 2026 by LFA Machines

www.lfamachines.com

United Kingdom

Unit 4B
Murdock Road
Bicester
Oxfordshire
United Kingdom
OX26 4PP

United States

6601 Will Rogers Blvd
Fort Worth
Texas
United States
76140

Germany

Business Parc Am
Trippelsberg 92
Düsseldorf
Germany
40589

Taiwan

7F.-5, No. 2, Sec. 2
Taiwan Blvd., West Dist.,
Taichung City 403,
Taiwan